

Vortex EF2280 Reference Manual

Polycom Moscow 
zakaz@polycom-moscow.ru
T +7 95-924-25-25
www.polycom-moscow.ru

| | |
|---|----|
| Introduction..... | 2 |
| <i>Product Features</i> | 3 |
| Pre-Installation..... | 4 |
| <i>EF2280 Front and Rear Panels</i> | 5 |
| Installation | 7 |
| <i>Mounting the EF2280</i> | 7 |
| <i>Connecting the EF2280 to Other Equipment</i> | 7 |
| <i>Device IDs on the EF Bus</i> | 9 |
| <i>Connecting Multiple EF2280s</i> | 9 |
| <i>Factory Default Settings (Preset 0)</i> | 11 |
| <i>Check Surrounding Equipment</i> | 13 |
| Integrating the EF2280 Into Your System..... | 15 |
| <i>Input Settings</i> | 15 |
| <i>Calibration</i> | 15 |
| <i>Build Your Echo Canceller Reference</i> | 17 |
| <i>Echo Canceller Reference for Multiple EF2280s</i> | 18 |
| <i>Configure the Automatic Microphone Mixer</i> | 20 |
| <i>Automixer Settings for Multiple EF2280s</i> | 22 |
| <i>Configure the Matrix Mixer</i> | 23 |
| <i>Building Your System with Multiple EF2280s</i> | 23 |
| <i>Presets</i> | 25 |
| <i>Other EF2280 Features</i> | 25 |
| LCD Menu Structure | 26 |
| <i>System Menu</i> | 29 |
| <i>Inputs</i> | 30 |
| <i>Outputs</i> | 31 |
| <i>Automixer Menu</i> | 32 |
| <i>Matrix Menu</i> | 34 |
| <i>Parametric EQ Menu</i> | 35 |
| Troubleshooting..... | 36 |
| <i>Automatic Microphone Mixer</i> | 36 |
| <i>Matrix Mixer</i> | 37 |
| <i>Echo Canceller Reference</i> | 37 |
| <i>Residual Echo</i> | 37 |
| <i>Contacting Technical Support</i> | 42 |
| Technical Specifications..... | 43 |
| <i>Compliance</i> | 43 |
| Conference System Design..... | 46 |
| EF2280 Block Diagram | 47 |
| Connector Pinouts..... | 48 |
| <i>Connecting Unbalanced RCA to Balanced Mini Phoenix</i> | 50 |
| <i>Making an EF Bus Terminator</i> | 50 |
| <i>Additional Notes</i> | 51 |
| Warranty Information..... | 52 |
| Definition of Terms | 54 |
| Index | 57 |

INTRODUCTION

Welcome

Congratulations on your purchase of the Vortex EF2280!

How to Use This Manual

This is a reference manual for your EF2280. It is structured to provide the information you need quickly and conveniently. The following is an overview of each section:

- *Introduction*
- *Conference System Design* gives suggestions on topics to consider when designing your system.
- *Pre-Installation* includes information about the contents of the box, tools needed for installation and front and rear panel descriptions.
- *Installation* covers connections of inputs/outputs and calibration of inputs of the EF2280.
- *Integrating the EF2280 Into Your System* describes adjustments to take into consideration when integrating the EF2280 with surrounding equipment in your system.
- *LCD Menu Structure* describes an overview of the LCD menu structure and also gives a system overview of features and options available.
- *Troubleshooting* helps to debug problems with installation.
- *Technical Specifications* provides the technical specifications of the EF2280.
- *EF2280 Block Diagram* shows the inside of the EF2280.
- *Connector Pinouts* shows pinout diagrams for EF2280 input and output connectors.
- *Warranty Information*
- *Definition of Terms* explains terms used in this manual, as well as terms used in our technology of echo cancellation, noise cancellation, and audio conferencing.

About the EF2280

The EF2280 is a 12-input, 12-output, 8-channel acoustic echo and noise canceller with matrix mixing and automatic microphone mixing capabilities. It includes a total of 12 analog inputs (8 mic/line level inputs and 4 line level inputs), 12 analog outputs, and 4 digital expansion busses. Acoustic echo cancellation (AEC) and noise cancellation can be applied to each of the 8 mic/line level inputs, and each of these inputs can then be sent to one of the two internal automatic microphone mixers. The system also contains a 25 x 18 main matrix, and four 7 x 3 submatrices. The 25 x 18 main matrix has the following inputs: input channels 1-8 (gated or ungated), input channels A-D, the internal signal generator, and 3 mixes of each of the four digital busses (3 mixes times 4 busses equals 12 inputs). The 25 x 18 main matrix has the following outputs: outputs 1-8 and A-D, AEC reference 1 and 2, and W, X, Y, and Z outputs to the digital expansion bus. The EF2280 has 24 bit resolution, 32-bit floating point computation, and a 48 kHz sampling rate.

Polycom's proprietary noise cancellation on each of the 8 mic/line inputs helps to keep overall ambient noise to a minimum. Polycom echo cancellers are the only ones on the market to feature this patent pending technology. Noise cancellation filters out ambient background noise such as noise from heating, ventilating and air conditioning (HVAC), LCD projectors, and road noise. Our noise cancellation technology is not a noise gate. It actually removes noise. Therefore, it enhances the operation and

improves the sound quality of an automixer, for example, by preventing it from bringing the noise level up and down when microphones are gated on and off. By cancelling the noise picked up by each microphone, the overall signal to noise ratio (SNR) is preserved. The result is crystal clear speech over a greater decibel range than any other echo canceller. That means reduced listener fatigue and a higher quality audio conference.

Warranty Registration

Please take a moment to fill out and return your warranty registration card. This information will help us to provide you with better customer support and will allow us to notify you with updated product features and software.

PRODUCT FEATURES

Product

- Front panel LCD for controlling and configuring the product without a computer
- 5-band equalizer on all Inputs and Outputs (Parametric, High/Low Pass, High/Low Shelf)
- Echo cancellation on Inputs 1-8
- Noise cancellation up to 15 dB
- Two internal automatic microphone mixers for Inputs 1-8
- 25 x 18 full cross point matrix mixer with expansion bus
- Internal signal generator for calibration mode and noise masking applications
- 2 year warranty

AEC

- 24 bit resolution
- 48 kHz sampling rate, >20 kHz bandwidth
- 270 ms AEC tail length
- 40 dB/sec convergence rate
- Can function in rooms with more than 10 dB of room gain

Inputs and Outputs

- 8 microphone/line level inputs with phantom power on each input
- 24 VDC Phantom Power
- 4 line level auxiliary inputs with nominal level of 0 dBu
- 12 digitally controlled analog trimpots for the 12 input signals
- 12 line level outputs with default nominal level of 0 dBu
- Automatic Gain Control (AGC) on Inputs 1-8.
- Phoenix connectors for audio input and output

Remote Control

- RS-232 port for remote control
- Reconfigurable parallel logic input/output
- ASPI bus for controlling multiple EF devices from a single controller
- EF bus for linking multiple EF2280s.
- Digital bus with 4 audio busses, 48 kHz sampling rate
- Up to 8 devices can be linked, each device providing 4 audio signals on the bus

PRE-INSTALLATION

What's Included

The Vortex EF2280 product package includes the following items:

- Vortex EF2280 Reference Manual
- Vortex EF2280
- External power supply
- Cat 5 cable for EF Bus or ASPI Bus
- EF Bus terminator
- Rack mount screws (4)
- Phoenix connectors (24)
- Cable clamp and screw
- CDROM containing other manuals and Conference Composer software
- Warranty Registration Card

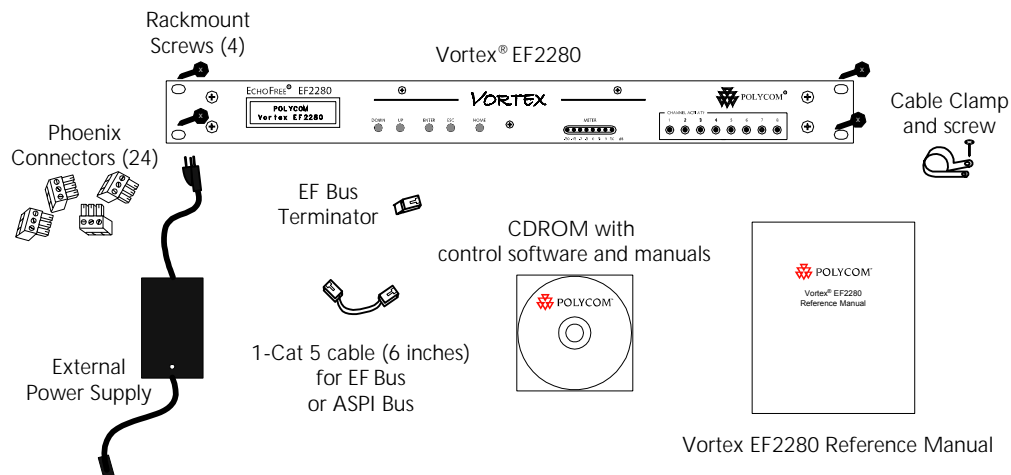

Figure 1. What's Included with your Vortex EF2280.

What's Not Included

The following equipment is not included with the EF2280 product package, but may be necessary to create a completely functional system:

- Microphones
- Loudspeakers
- Audio amplifier (or amplified loudspeaker)
- EF200 Phone Add
- Audio cables
- Videoconferencing codec or other four-wire interface (optional)
- RS-232 remote control device (optional)

Tools Needed for Installation

- Screwdriver to mount the EF2280 in your rack.
- Phoenix connector screwdriver

EF2280 FRONT AND REAR PANELS

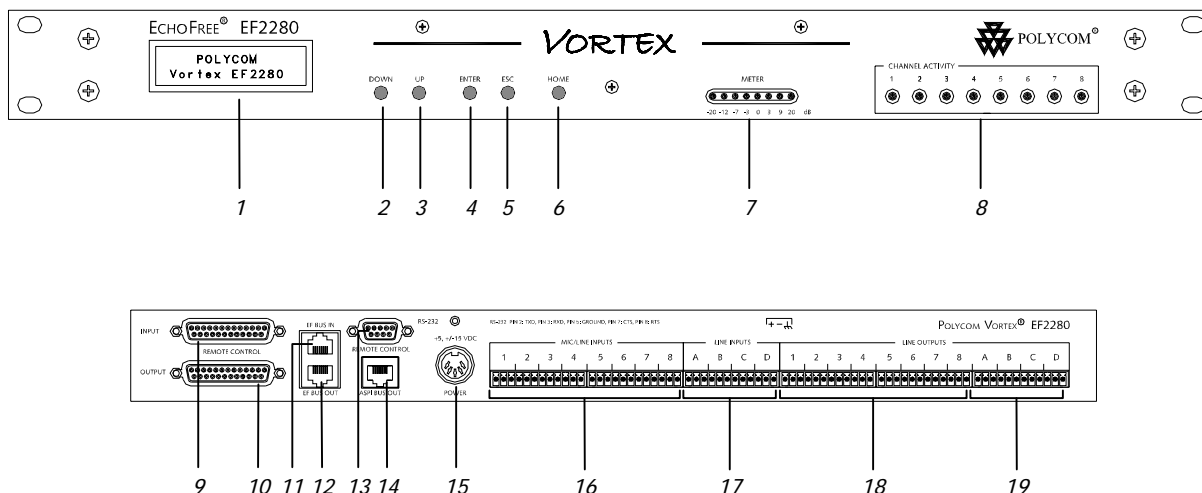

Figure 2. EF2280 Front and Rear Panels

1. LCD DISPLAY. Displays menu instructions for configuration and operation of the EF2280.
2. DOWN BUTTON. Scrolls backward through menu items at a particular level or decreases the value of a parameter.
3. UP BUTTON. Scrolls forward through menu items at a particular level or increases the value of a parameter.
4. ENTER. Enters the menu and allows you to select and change parameter values.
5. ESC. Returns to the next highest level of menus.
6. HOME. Returns to the top of the menu structure.
7. LEVEL INDICATOR. Indicates the level of the selected channel or parameter.
8. CHANNEL ACTIVITY LEDs. Indicates gating activity of the 8 mic/line channel inputs.

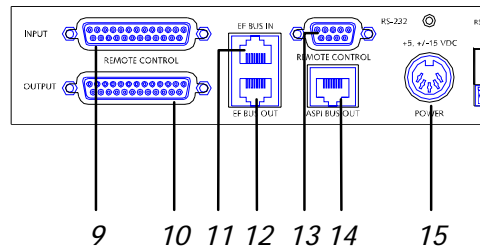

Figure 3. Parallel remote control, EF BUS, serial remote control, ASPI BUS OUT, and power supply input on back panel of the EF2280.

9. INPUT PARALLEL PORT. Parallel logic input.
10. OUTPUT PARALLEL PORT. Parallel logic output.
11. EF BUS IN. Connects to EF BUS OUT of another EF2280.
12. EF BUS OUT. Connects to the EF BUS IN of another EF2280.
13. RS-232 SERIAL PORT. Connect this to an optional RS-232 remote control device, such as a touch panel or personal computer COM port.
14. ASPI BUS. Connects to the ASPI Bus of another EF device (an EF1210 or an EF200) to be used for RS-232 control from a single control device.
15. POWER SUPPLY INPUT. Connects to the external power supply provided with the EF2280.

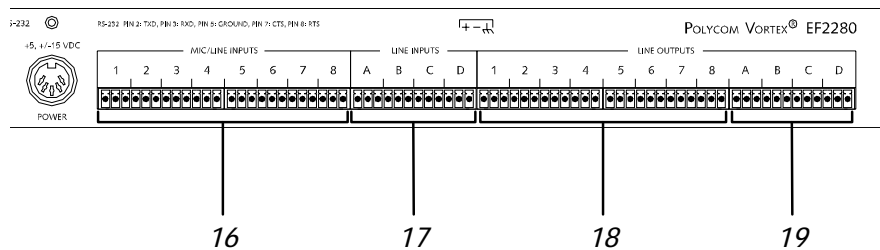

Figure 4. Inputs and outputs on back panel of the EF2280.

16. MIC/LINE INPUTS. Connects to microphone at either mic or line level, with or without phantom power.
17. LINE INPUTS. Inputs A-D at line level.
18. LINE OUTPUTS. Outputs 1-8 at line level.
19. LINE OUTPUTS. Outputs A-D at line level.

INSTALLATION

MOUNTING THE EF2280

The EF2280 can be mounted in a rack enclosure using four large screws (10-32x1/2") included with the unit. One EF2280 fits in a single rack space.

Recommendation For Easy Access

While not required, leave a single rack space in between the EF2280 and other units in your rack. This gives you easier access to the back panel. If you cannot leave a single rack space, mount the EF2280 **below** units that are longer in length so that you can access the Phoenix connectors on the back panel more easily.

Instructions for Securing Power Supply to Back of EF2280

- Locate the cable clamp on the back panel of the EF2280 above the RS-232 port.
- Remove the screw and thread the power cord through the cable clamp.
- Attach the cable clamp to the back panel of the EF2280 and tighten the screw. Align the clamp so that the power cable does not interfere with the connectors on the EF2280 back panel.
- Plug in the power supply.
- We recommend that you also Ty-wrap the power supply to the rack. The purpose of securing the power supply to the back panel is so that if the power supply were to drop, it would pull where the cord is attached with the cable clamp and not pull the plug out of the EF2280.

Caution! *Do not use any other power supply other than the one provided with this unit.*

CONNECTING THE EF2280 TO OTHER EQUIPMENT

Grounding

The EF2280 has 8 mic/line inputs plus 4 line level inputs and 12 line level outputs. Each input/output is "Pin 1 compatible" — this means that the ground pin of each input/output is tied to chassis ground. Chassis ground is connected to the input power ground.

Typical EF2280 Connections

The EF2280 will typically be connected to other equipment in a single room setup as shown below in Figure 5 and Figure 6.

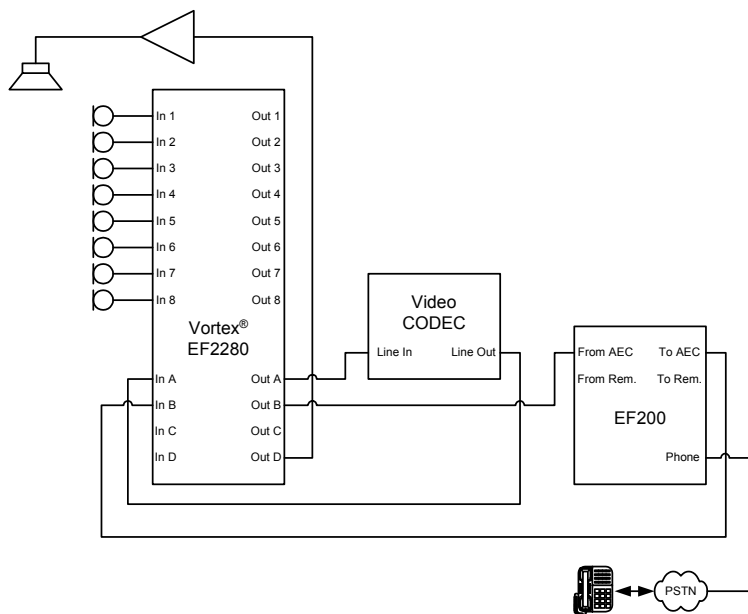

Figure 5. Block diagram of typical EF2280 connections: a single room using one EF2280.

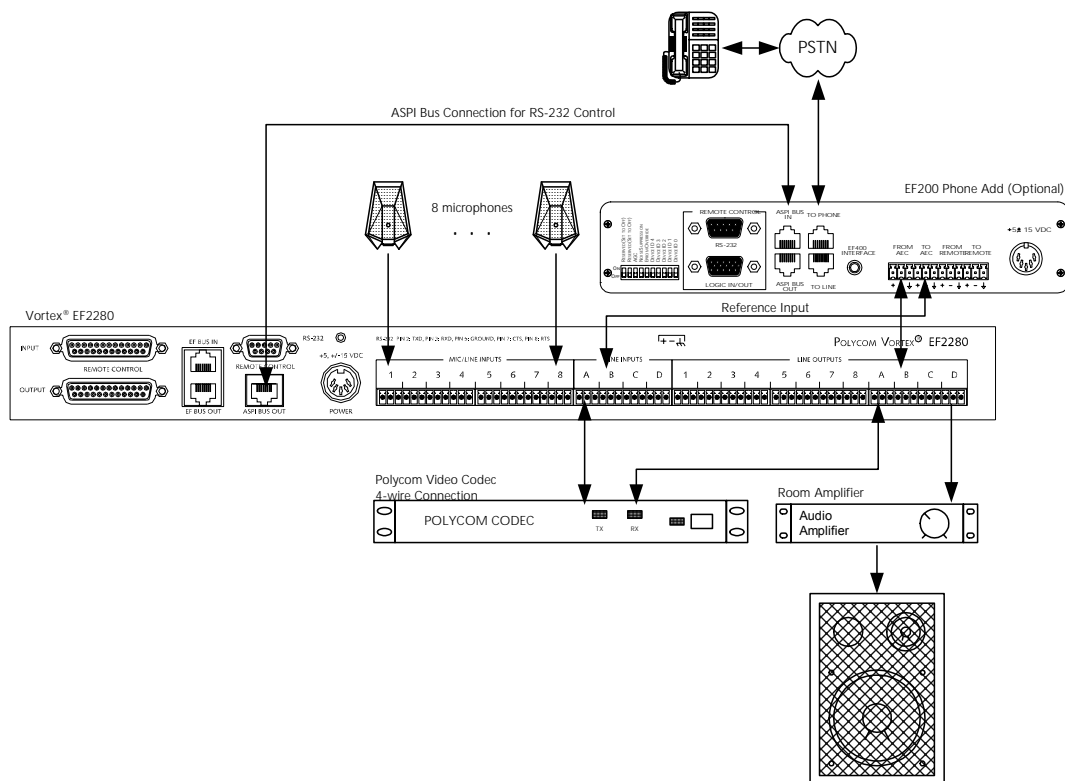

Figure 6. Typical EF2280 connections.

The following steps are typically used to setup the EF2280:

- Connect a microphone to each of the 8 mic/line level inputs. The mic/line input accepts mini-Phoenix connectors. See “Connector Pinouts” on page 48 for pinouts of Phoenix connectors.
- Connect one line output to an amplifier or powered loudspeaker.
- Connect the reference input (Input A, B, C, or D) to TO AEC on the EF200 (if you have multiple EF200’s, connect only one reference) or to the output of the codec.
- Connect one line output to FROM AEC on the EF200 or to the input of your codec.
- If RS-232 remote control is desired, connect the RS-232 REMOTE CONTROL port of the EF2280 to the remote control device, such as an RS-232 interface to a touch panel or a COM port on a personal computer. If you are using an EF200 Phone Add, connect the ASPI BUS on the EF2280 to the ASPI BUS IN on the EF200.

Note. If you are linking multiple EF2280s, you must use the EF bus to link the units. If you are linking a EF2280 to other EF devices, such as the EF200 Phone Add, for RS-232 control, use the ASPI bus. See Figure 8 on page 11.

- Connect the external power supply to the POWER SUPPLY INPUT jack of the EF2280.

DEVICE IDS ON THE EF BUS

When considering which Device IDs can be used for which Vortex device, decide how many devices have the ability to **transmit** on the W, X, Y, and Z busses, and how many have the ability to transmit on the P Bus. The EF2280, for example can only transmit on the W, X, Y, and Z busses while the EF2241 can transmit on the W, X, Y, and Z busses as well as the P bus. Up to 8 devices can transmit on the W, X, Y, and Z busses. Similarly, up to 8 devices can transmit on the P bus. Note that the EF2241 counts as one of both types.

CONNECTING MULTIPLE EF2280s

Up to 8 EF2280s can be linked together at one time. Each unit in the chain must have a unique Device ID. Use the EF Bus to link multiple EF2280s together.

The following steps should be followed to connect the EF Bus:

1. Set a unique Device ID for each EF2280
2. Power off all units
3. Connect the RS-232 remote control device to any EF2280 in the chain.
4. Connect the provided Cat-5 cable between the EF BUS OUT of the first device, and the EF BUS IN of the second device.

Note. The EF Bus must be connected so that the EF Bus In of one box is connected to the EF Bus Out of another. Connecting the EF Bus In to another EF Bus In (or Out to Out) will not work.

5. Connect another Cat-5 cable between the EF BUS OUT of the second device and the EF BUS IN of the third device, and so on.
6. Terminate the chain of EF2280s using the instructions below.
7. Power on all units at the same time

Terminating the EF2280

The EF2280 must be terminated with the provided EF Bus terminator. Place a terminator in the EF BUS IN of the first device in the chain and also in the EF BUS OUT of the last device. If you lose the terminator provided with your EF2280 unit, see “Making an EF Bus Terminator” on page 50 for information and instructions on how to make one.

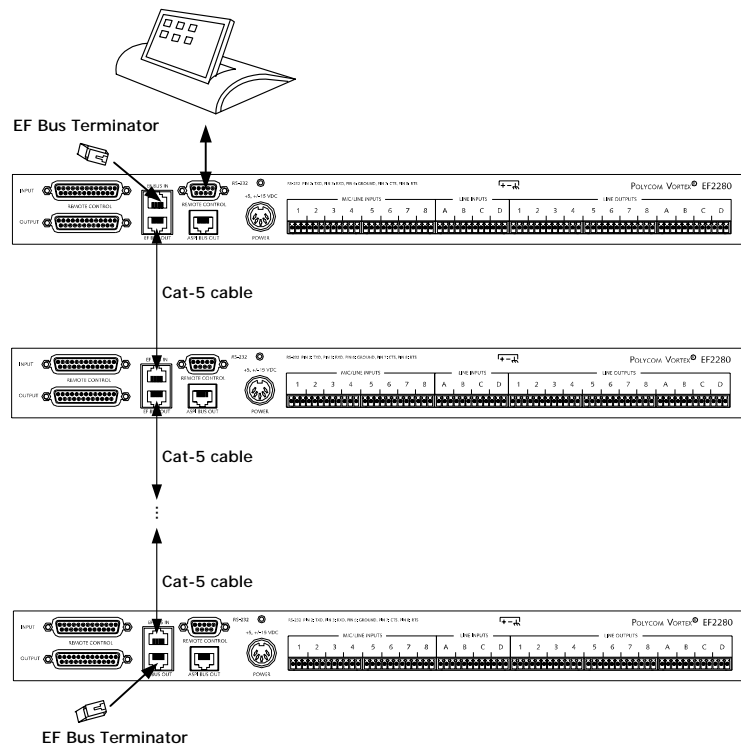

Figure 7. Connecting and terminating multiple EF2280s.

The EF2280 does not have to be terminated if you are using a single unit not connected together with another EF2280.

Connecting the EF2280 with Other EF Devices

If you are linking multiple EF2280s, you must use the EF bus to link the EF2280s to each other. If you are linking a EF2280 to other EF devices, such as the EF200 Phone

Add, for RS-232 control, use the ASPI bus. The ASPI Bus does not need to be terminated. See Figure 8 below.

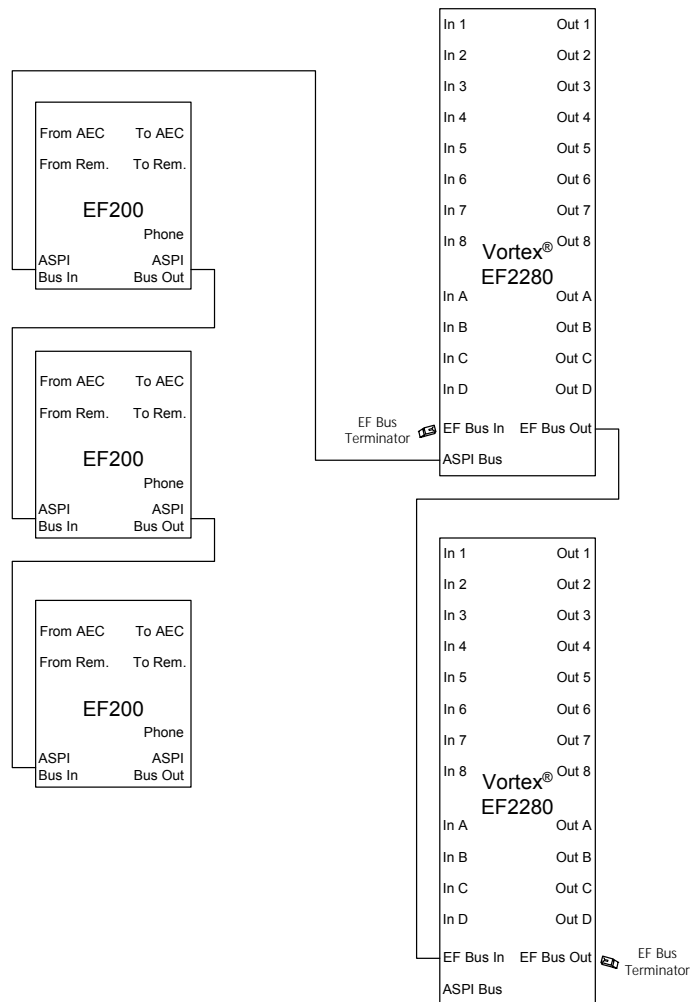

Figure 8. Linking the EF2280 to other EF devices.

FACTORY DEFAULT SETTINGS (PRESET 0)

The following is a list of the factory default settings of the EF2280. Since the microphones and other equipment in your application may have different nominal levels, you can start with a FACTORY PRESET (Presets 0-15), change it to match your environment and then save it within the EF2280 as a USER PRESET (Presets 16-47). Once you've saved a USER PRESET, set the POWER ON PRESET to that USER PRESET (or

whichever preset you want to come up after power up). The unit will need to be configured for your system.

| PROGRAM PARAMETERS | FACTORY DEFAULT PRESET VALUE |
|----------------------------|---|
| SYSTEM PARAMETERS | |
| Preset | 0 |
| Device ID | 0 |
| AUTOMIX PARAMETERS | |
| Chairman Mode | Off |
| Decay Time | 1000 ms |
| Hold Time | 500 ms |
| Last Mic On Mode | On (on Automixer 1) |
| Max NOM per Automixer | 8 |
| Off Attenuation | -15 dB |
| INPUT CHANNELS | |
| Acoustic Echo Cancellation | On |
| Automatic Gain Control | On |
| Automixer | 1 |
| Echo Canceller Reference | Ref1 |
| Filtering | Off |
| Gate Priority | 1 |
| Gate Ratio | 10 dB |
| Gate Threshold | Adaptive |
| Gating | Auto |
| Input Gains | 15 dB for Inputs 1-8 0 dB for Inputs A-D |
| Manual Threshold | 60 dB |
| Mute | Off |
| Noise Cancellation | On |
| Noise Cancellation Level | 10 dB |
| Phantom Power | On |
| OUTPUT CHANNELS | |
| Mute | Off |
| NOM Attenuation | Off for Outputs 1-8 On for Outputs A-D |
| Output Gain | 0 dB |

Presets and Multiple EF2280s

PRESET 0 is preconfigured for a system with multiple EF2280s. Microphones are bussed out to other units on the W Bus. Microphones are also input into each EF2280 on the W Bus (INPUT WM0 in the Matrix).

If you have multiple EF2280s in your system, save settings to a preset on each EF2280. Saving a preset will only save the preset on that particular unit. Also, remember to set the POWER ON PRESET to the correct Preset.

CHECK SURROUNDING EQUIPMENT

Now that the physical connections to the EF2280 are set up, it may be necessary to check the surrounding equipment to make sure levels are set correctly. The following suggestions may be helpful in integrating the EF2280 into your system:

Pick a Standard Signal Level

A standard nominal signal level should be used throughout the audio system. Any equipment that does not operate at this standard level should be compensated for as close to the piece of equipment as possible. A 0 dB nominal level is a good standard signal level. For example, a consumer VCR will probably generate a -8 dBu level. As soon as the VCR signal arrives at an input with some gain control, the input gain should be adjusted so that you get a 0 dB level.

Check Levels to the Codec

Configure the matrix mixer output to the codec input. The output gain of the matrix mixer should be set to match the nominal input level of the codec. For example, if the codec accepts -10 dBV (-8 dBu) inputs, 8 dB of attenuation should be applied at the matrix mixer output to the codec.

Configure the matrix mixer input from the codec output. The input gain of the matrix mixer should be set to match the nominal output level of the codec. For example, if the codec outputs a -10 dBV (-8 dBu) level, 8 dB of gain should be applied on the matrix mixer input. This will bring the codec level up to 0 dBu inside the matrix.

Configure Output to Amplifier or Loudspeakers

The loudspeaker level may be adjusted in several places: at the amplifier or at the loudspeaker output of the matrix mixer in the EF2280. We suggest that you adjust the loudspeaker level at the amplifier to preserve good gain structure. You should try to have a 0 dBu nominal level at the outputs by applying input gain (See INPUTS tab on Conference Composer) to obtain a 0 dB level at the input.

Verify Room Gain

After adjusting the loudspeaker level, verify the room gain in your system using the ROOM GAIN meter on the DIAGNOSTICS page of Conference Composer. See Figure 9 below. The meter shows the room gain, which is the relative level of the output level and the input level. While the EF2280 will operate in positive room gain conditions, the room gain should be around 0 dB or a negative value. If you have a positive room gain, make adjustments in the following areas:

1. Decrease the Input Gain of the microphone.
2. Decrease the Output Gain of the microphone.

- OR adjust the placement of the microphone relative to the loudspeaker.

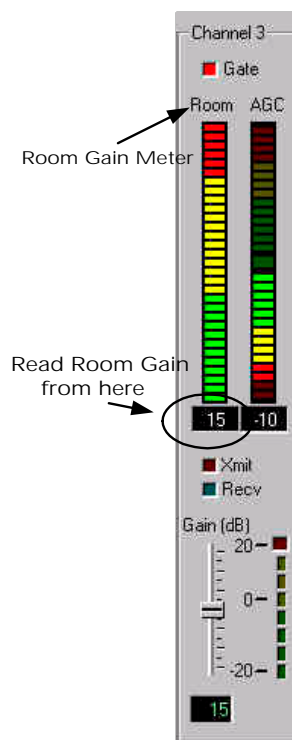

Figure 9. Room Gain Meter on the Diagnostics page of the Conference Composer control software.

Configure Program Audio Sources

Set the gains on the matrix mixer inputs from the program audio sources so that program audio is played into the room at a level similar to that of speech from the remote site. This should also ensure that the program audio levels are good when sent to the remote site.

INTEGRATING THE EF2280 INTO YOUR SYSTEM

Operating the EF2280

The EF2280 can be operated in two ways: through the LCD menu on the front panel or through RS-232. For control via RS-232, please refer to the EF2280 Programming Guide, which includes programming tips as well as the EF2280 RS-232 commands. For operation using the PC control software, Conference Composer, please refer to the Conference Composer User Guide.

Use Conference Composer Software to easily configure the EF2280 with a PC, or refer to the Applications Guide for different configurations that are already programmed into factory presets.

INPUT SETTINGS

Set Inputs 1-8 for Mic or Line Level

Configure Inputs 1-8 for mic or line level using the LCD menu (See “Level” on page 30) or Conference Composer Control Software (See the Conference Composer User Guide).

Select Phantom Power for Inputs 1-8

Turn phantom power On or Off for Inputs 1-8 using the LCD menu (See “Phantom Power” on page 31) or Conference Composer Control Software (See the Conference Composer User Guide). Phantom power should be turned On for condenser and electret microphones.

CALIBRATION

When using the power on Preset 0, the following calibration can be used.

Set Mic/Line Input Channel Gains

In Preset 0, Automatic Gain Control (AGC) is On and the microphone gains on Inputs 1-8 are set to 15 dB. The AGC will compensate for the microphone gain. If you are using ceiling microphones, set the microphone gain to 28 dB.

Fine tune the Input Gain using the Automatic Gain Control (AGC) meter on Conference Composer Software.

In the Conference Composer Software, go to the DIAGNOSTICS page. Watch the meter labelled AGC while someone is talking into the particular channel that you are adjusting. Watch the number in the box at the bottom of the AGC meter (See Figure 10 below). This is the amount of gain that the AGC is applying. The goal is to have the AGC meter on average staying around 0. If the level that you see in the box is negative, decrease the input gain by the average number that you see in the box because the AGC is attenuating the channel’s input gain because the level is too high. If the number in the box is positive, increase the input gain on that channel because the AGC is boosting the signal because it is too low. For example, if the meter is showing an average gain of -15 dB,

you should increase your input gain by 15 dB. If the meter shows an average gain of +10 dB, you should decrease your input gain by 10 dB.

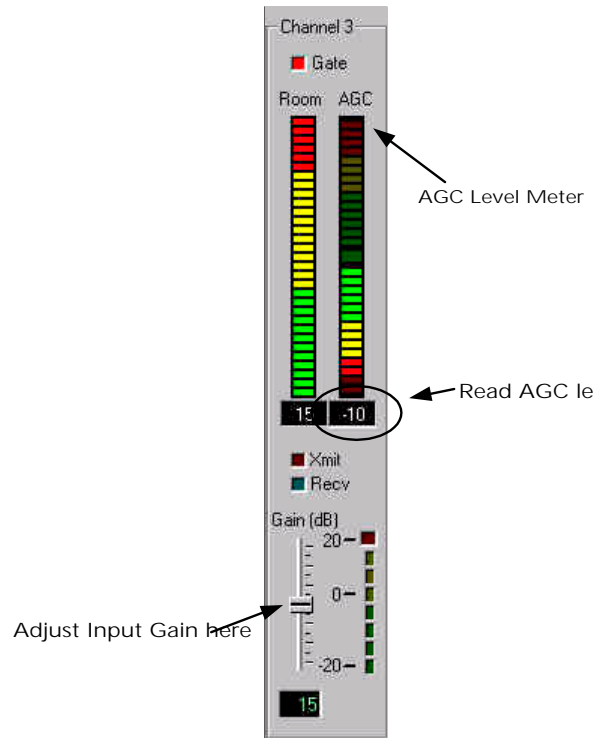

Figure 10. AGC Meter on the Diagnostics page of the Conference Composer software.

| IF THE AGC METER SHOWS... | ADJUST THE INPUT GAIN IN THIS WAY. |
|---------------------------|--|
| positive gain | Increase gain by the level shown in the box. |
| negative gain | Decrease gain by the level shown in the box. |
| an average level of 0 dB | You've set the Input Gain to a good level! |

Table 1: How to set the Input Gain using the AGC meter on the Conference Composer Diagnostics page.

Set Levels on Line Input Channels

Set the line input channel gains (Channels A-D) to match the nominal level of the incoming equipment. The line inputs have a maximum nominal level of 0 dBu. If your incoming line level inputs have a higher nominal level than 0 dBu you will want to use a pad to remove the level.

*Customize Setting
for Your Particular
Application*

The following sections will describe customizing parameters on the EF2280 for your particular application if you are not using Preset 0.

BUILD YOUR ECHO CANCELLER REFERENCE

The acoustic echo canceller (AEC) reference should generally contain exactly the same audio signals as what is coming out of your loudspeaker(s), since the signal output from the loudspeaker is what is then picked up by the room's microphones causing acoustic echo. Note that this statement is a general statement. Conditions for this being true follow:

*If your system does
NOT have sound
reinforcement,*

- The AEC reference should contain exactly the same audio as the loudspeaker output: all far end audio, audio from the phone add, program audio, etc.
- If your system contains stereo inputs and outputs, the reference must contain a mix of both stereo inputs. For example, if your VCR audio is in stereo, the reference should contain both the left and right signals each attenuated by 3 dB, as well as any other audio that is going to your loudspeaker.
- If you are using crosspoint gains in the loudspeaker mix, apply the same gains to the signals in your reference.

*If your system has
sound
reinforcement,*

- Do NOT mix your room microphones into the reference, but include all other audio (program audio, remote audio, phone audio, etc.).
- An exception to this rule is when you use one EF2280 split to operate independently in two rooms. If the two rooms communicate with each other (along with communicating via codec and the phone line), the reference in the first room must contain the microphones from the second room and vice versa. See Figure 11 below.

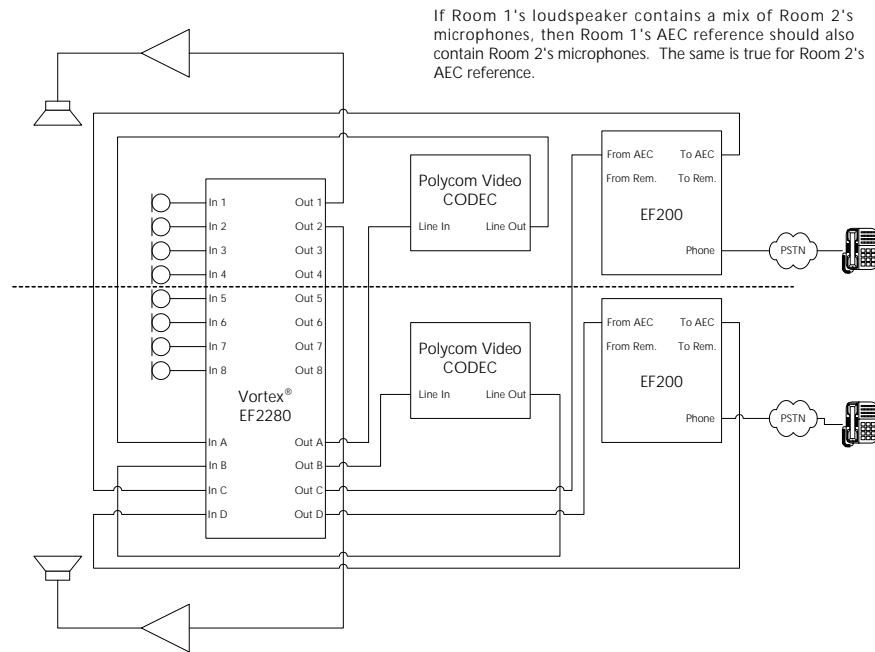

Figure 11. AEC reference for two rooms that communicate with each other with one EF2280.

ECHO CANCELLER REFERENCE FOR MULTIPLE EF2280S

In a system with multiple devices, we recommend that one device be designated as the unit that provides the EF bus reference for the acoustic echo cancellers. This unit takes one of its reference signals (either Ref 1 or Ref 2) and places it on the EF bus. All other units that are linked together may use the EF bus reference as the reference for their echo canceller, or they can use their own internal references. The references may include a mix of any input, with crosspoint gains, including W, X, Y, and Z buses. Set the EF Bus Reference in the System Menu of the LCD Menu (See “EF Bus Reference” on page 29).

Setting up the Bus Reference

If all far end audio and program audio sources are on the same EF2280,

1. Assign far end audio and program audio sources to Reference 1 on the originating EF2280.
2. On the EF Bus page in Conference Composer for the originating EF2280, set the Exported Signals to REFERENCE 1. Only one EF2280 can put an echo canceller reference on the EF Bus as the Bus Reference.
3. On all linked EF2280s, set the echo canceller reference to BUS.

For example, a system uses 2 EF2280s, 1 EF200, and 1 Polycom VS4000 video codec. The originating sources for far end audio is EF2280 with ID 0. The Matrix for

this EF2280 in Conference Composer is shown in Figure 12 and the EF Bus page in Figure 13. Conference Composer will not allow more than one EF2280 assign their echo canceller reference as the Bus Reference. Notice that the EF200 and VS4000 inputs are both assigned to Reference 1 on the originating EF2280. The Matrix for any linked EF2280s is shown in Figure 14.

Figure 12: Matrix page of origin EF2280 (ID 00)

This matrix shows the routing of signals from various inputs to outputs. The columns represent inputs (IN, 1-8, A, B, C, D, W, X, Y, Z, R1, R2, Mixer, AEC) and the rows represent outputs (OUT, NDM, Mic 1-8, VS4000 codec, EF200, Mics 9-16, SubMix X0-M2, Y0-M2, Z0-M2, PM0-M1, Signal Generator). The 'Reference' column (R1, R2) indicates which input is assigned as the reference for each output. For example, Mic 1, Mic 2, and Mic 3 are assigned to Reference 1, while Mic 4, Mic 5, and Mic 6 are assigned to Reference 2. The 'Safety Mute' button is visible at the top left.

Figure 12. Matrix page of origin EF2280 (ID 00)

Figure 13: EF Bus page of origin EF2280 (ID 00)

This page displays the EF Bus configuration, showing connections between various bus channels. The columns represent EFBus channels (wB0-wB7, xB0-xB7, yB0-yB7, zB0-zB7, pB0-pB7) and the rows represent the corresponding bus channels. The 'Safety Mute' button is at the top right. The 'Exported Signals' section at the bottom shows the current unit exporting signal EF2280:00. A note states: "Note: Only one unit can place a reference signal on the EFBus at one time. If you need to create a reference signal across multiple units, use the W, X, Y, and Z bus channels." The 'T O M A T R I X' label is on the right side.

Figure 13. EF Bus page of origin EF2280 (ID 00)

Figure 14: Matrix page of linked EF2280s

This matrix shows the routing of signals from various inputs to outputs for linked EF2280s. The columns represent inputs (IN, 1-8, A, B, C, D, W, X, Y, Z, R1, R2, Mixer, AEC) and the rows represent outputs (OUT, NDM, Mic 9-16, SubMix X0-M2, Y0-M2, Z0-M2, PM0-M1, Signal Generator). The 'Reference' column (R1, R2) indicates which input is assigned as the reference for each output. For example, Mic 9, Mic 10, and Mic 11 are assigned to Reference 1, while Mic 12, Mic 13, and Mic 14 are assigned to Reference 2. The 'Safety Mute' button is at the top left.

Figure 14. Matrix page of linked EF2280s

If far end audio and program audio sources are on several EF2280s,

1. Bus each far end audio and program audio source to each EF2280. Do this by assigning each signal input to either the W, X, Y or Z bus.
2. Assign an echo canceller reference on each EF2280 that will include all far end audio and program audio sources.

CONFIGURE THE AUTOMATIC MICROPHONE MIXER

The EF2280 contains two independent automatic microphone mixers. Each input may be assigned to automatic mixer 1, automatic mixer 2, or neither (but not both). Assign all microphones to the same automixer when using all microphones in the same room but in different zones, so that a person does not activate microphones in two different zones (which they would tend to do if each zone had its own automatic mixer). Use both automatic mixers when the EF2280 is split to operate independently between two rooms. One automatic mixer is used in each room. The advantage of having two independent automatic mixers is that when used in two rooms, microphone signals in one room do not affect the gating behavior of microphones in the other room. Set an input channel to use neither automatic mixer if an input is not actually a microphone, but is a program audio input. For instance, if you only have 6 microphones and you have an extra stereo program audio source that you want automatic gain control (AGC) on and/or noise cancel, you could set its channels to be on neither automatic mixer.

If you have a PC, use the Conference Composer software (See the Conference Composer User Guide) to set the automixer parameters. If you would like to set automixer parameters using the LCD menus, see “Automixer Menu” on page 32 for instructions on setting automixer parameters.

Automixer Parameters

The following parameters configure how the EF2280 automatic microphone mixer operates. Parameters include the following: Decay Time, Hold Time, Camera Gating Threshold, Chairman Mode, Chairman Mic, Last Mic On Mode, Last Mic Number, Local Max NOM, Global Max NOM, Off Attenuation, Threshold Type, Gating Mode, Gate Ratio, Manual Threshold, and Microphone Priority.

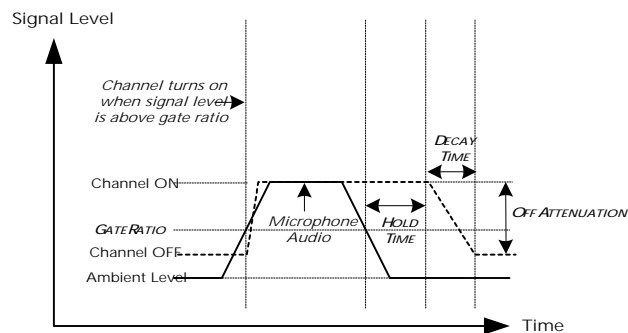

Figure 15. Off Attenuation, Hold Time, Gate Ratio, and Decay Time.

Global Settings.

Decay Time. Decay time is the amount of time the microphone audio takes to ramp down to the Off Attenuation level after Hold Time. Decay Time values range from 0 to 5000 msec. The default value is 1000 msec.

Hold Time. This is the amount of time the microphone stays On after the energy in the channel drops below the gating threshold. The default value is 500 msec. The range is 1 to 5000 msec. Microphone channels gating On and Off too frequently during short pauses in speech might be the result of setting the Hold Time too low while too many microphones gating on at the same time may be the result of Hold Time values that are too high.

Camera Gating Threshold. Specifies the hold time for camera gating information.

Mixer Settings.

Bus Mixer. This command is used to assign one of the two internal automixers to one of the EF Bus automixer groups. For example, consider three EF2280s each of which has four microphones assigned to Automixer 1 and 4 microphones assigned to Automixer 2. Now, if each of these EF2280s sets their Automixer 1 to use Bus Mixer 5, then the three automixers (one from each EF2280) will work as a single automixer containing 12 (3 x 4) microphones. Setting Bus Mixer to 0 means that the automixer is not grouped on the EF Bus.

Chairman Mode. Enables or disables Chairman Mode for the specified automixer.

Chairman Mic. Sets the Chairman Microphone for the specified automixer.

Last Mic On Mode. Sets “Last Mic On” mode for the specified automixer.

Last Mic Number. Sets the microphone number that will remain on when “Last Mic On” mode is set to manual. Setting this value to 0 will cause the automixer to leave the last open microphone on. The last microphone number is specified for each automixer, but is only used in manual “Last Mic On” mode.

Local Max NOM. Sets the maximum number of open microphones (NOM) limit for the specified automixer. This NOM limit is a “local” limit, meaning that this limit applies only to the specific EF2280 that it is set on.

Global Max NOM. Sets the global maximum number of open microphones (NOM) limit for each linked automixer. The maximum value for this command is 64. This NOM limit is a “global” limit, meaning that this limit applies to all linked automixers with the same Bus ID.

Off Attenuation. Sets the Off Attenuation (in dB) for the specified automixer. Setting this value to 18 would result in the microphone signals being attenuated by 18 dB when gated off. This value is set independently for each of the automixers.

Channel Settings.

Automixer (Inputs 1-8). This allows you to select which automatic microphone mixer (1 or 2) a particular microphone channel is assigned to. A microphone may only be assigned to automatic mixer 1, automatic mixer 2, or neither (but not both).

Threshold Type. Sets automatic (also referred to as adaptive) or manual automatic gating thresholds per input.

Gating Mode. Sets the automixer gating control mode for specified input channel. The possible modes are Normal Gating, Microphone Forced On, or Microphone Forced Off.

Adaptive Threshold. This allows you to determine when to gate a microphone on based on an estimate of the background noise level. The default value is to

gate a channel on if it is more than 10 dB louder than the background noise level. Values range from 0 to 100 dB. To set the gate ratio, scroll through the gate ratio range and select the desired gate ratio by pressing ENTER.

Manual Threshold. Sets the automixer gating threshold for the specified input channel. This value is only used if the input set to Manual Gating via the THRESHOLD TYPE option.

Microphone Priority. The priority of each microphone can be assigned a value ranging from 1 to 4. Priority 1 microphones have priority over priority 4 microphones for gating. The default is to have all microphones set to priority 1. If Chairman Mode is enabled, all microphones including ones with priority of 1 will be gated off when the Chairman mic gates on.

AUTOMIXER SETTINGS FOR MULTIPLE EF2280S

When using more than one EF2280 in your room system, you have several possibilities for how you configure the automixer. Each EF2280 can operate as one of the following:

- One automixer, independent of other EF2280s linked to it
- Two automixers, independent of other EF2280s linked to it
- One large automixer, sharing automixer functions with other EF2280s linked to it
- Two large automixers, sharing automixer functions with other EF2280s linked to it

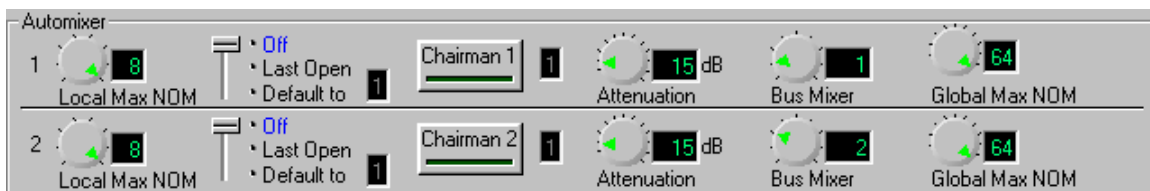

Figure 16. EF2280 Automixer Settings in Conference Composer Software

Automixer and Bus Mixer Settings

To operate the EF2280 in any of the above possibilities, two global parameters need to be changed: the AUTOMIXER and the BUS MIXER (see Figure 16). The AUTOMIXER parameter chooses which automixer the input channel will be on (this is changed either on the AUTOMIXER page in Conference Composer or on the MATRIX MIXER page).

The BUS MIXER parameter is used to assign one of the two internal automixers to one of the EF Bus automixer groups. For example, consider three EF2280s each of which has four microphones assigned to Automixer 1 and 4 microphones assigned to Automixer 2. Now, if each of these EF2280s sets their Automixer 1 to have Bus ID 5, then the three automixers (one from each EF2280) will work as a single automixer containing 12 (3 x 4) microphones. Setting BUS MIXER to 0 means that the automixer is not grouped on the EF Bus.

Operating as an Independent Automixer

To set the EF2280 to operate as an independent automixer (or two), set the BUS MIXER parameter to 0, or to a number that is different from any other automixer group on the EF Bus.

Operating as One Automixer with Multiple EF2280s

To set the EF2280 to operate as one automixer across several EF2280s, set the BUS MIXER parameter on all EF2280s to the same automixer group.

Default Settings

In the default preset (Preset 0), the Bus Mixer for Automixer 1 is set to 1 and the Bus Mixer for Automixer 2 is set to 2. This means that in the default mode, all linked EF2280s will work together as one complete automixer.

CONFIGURE THE MATRIX MIXER

The matrix mixer allows arbitrary crosspoint gains in 1 dB increments between any input and output signal.

If you have a PC, use the Conference Composer software (See the Conference Composer User Guide) to set the matrix parameters. If you would like to set matrix parameters from the LCD menus, see “Matrix Menu” on page 34 for descriptions and instructions on setting matrix mixer parameters.

BUILDING YOUR SYSTEM WITH MULTIPLE EF2280S

The following is a checklist for building a system with multiple EF2280s:

1. Assign Inputs.
2. Assign Outputs.
3. Configure submatrix (the EF Bus).
4. Configure your echo canceller reference.

1. Assign Inputs

Assign each audio source to an input. Remember to include the conferencing equipment such as the EF200 Phone Add or a video codec and any program audio.

2. Assign Outputs

Try to assign as many outputs as you can to each EF2280 to make a simpler submatrix. Remember that Outputs 1-8 can also be used as outputs of the matrix. The busing can get very complicated very quickly if you choose to spread your outputs over several units.

3. Configure the submatrix.

To link multiple EF2280 devices together, use the submatrix on the EF Bus.

The EF Bus

The EF Bus is a high speed, low delay digital bus that includes the W, X, Y, and Z audio busses as well as the echo canceller reference and remote control information (for other EF2280s) and can link up to 8 EF2280 devices. All busses include NOM information and can be used for sharing microphone inputs, or for sharing mono or stereo program information.

Crosspoint Mix Minus Bus. Each EF2280 device in the system can create four output mixes (W, X, Y, and Z) and place them on the bus. Each device also can create three input mixes each from the W, X, Y, and Z busses of the other devices (for a total of 12 mixes). The mixes can have crosspoint gains on the signals from the other devices. See Figure 17 below. All 12 mixes become inputs to the main matrix and can be mixed with the other inputs to create outputs 1-8, A-D, Ref 1, Ref 2, and W, X, Y, and Z bus outputs.

Submatrix

| | | | | | | | | |
|--------------|-----------------------|-----------------------|-----------------------|-----------------------|-----------------------|-----------------------|-----------------------|-----------------------|
| Bus W | W_B0 | W_B1 | W_B2 | W_B3 | W_B4 | W_B5 | W_B6 | W_B7 |
| | | | | | | | | |
| | | | | | | | | |
| | | | | | | | | |
| Bus X | X_B0 | X_B1 | X_B2 | X_B3 | X_B4 | X_B5 | X_B6 | X_B7 |
| | | | | | | | | |
| | | | | | | | | |
| | | | | | | | | |
| Bus Y | Y_B0 | Y_B1 | Y_B2 | Y_B3 | Y_B4 | Y_B5 | Y_B6 | Y_B7 |
| | | | | | | | | |
| | | | | | | | | |
| | | | | | | | | |
| Bus Z | Z_B0 | Z_B1 | Z_B2 | Z_B3 | Z_B4 | Z_B5 | Z_B6 | Z_B7 |
| | | | | | | | | |
| | | | | | | | | |
| | | | | | | | | |

Figure 17. W, X, Y, and Z submatrices.

EF Bus Reference. In a system with multiple devices, if all devices need the same echo canceller reference, one device should be designated to put its echo canceller reference (either Ref 1 or Ref 2) on the EF bus to be used as the EF Bus Reference. All other EF2280s may use the EF bus reference as the reference for their echo cancellers, or they can use their own internal references. The references may include a mix of any input, with crosspoint gains, including W, X, Y, and Z busses.

NOM Bus. All busses on the EF Bus contain NOM information. See HeadingRun(page 31) for more information on how NOM attenuation is applied.

Note. *The EF Bus must be connected so that the EF Bus OUT of one EF2280 device is connected to the EF Bus IN of another EF2280. Connecting EF Bus IN to another EF Bus IN (or EF Bus OUT to EF Bus OUT) will not work. See "Connector Pinouts" on page 48 for pinout of Cat 5 cable.*

4. Configure Your Echo Cancellor Reference

Review what inputs need to be included in your echo canceller reference — See “Build Your Echo Cancellor Reference” on page 17. Remember that each microphone needs to have an echo canceller reference. If all microphones are in the same room and use the same reference, configure the echo canceller reference on one EF2280 and assign it to the EF Bus as the EF Bus Reference. Only one EF2280 out of multiple units linked together can put an echo canceller reference on the EF Bus. For each additional unit, assign the echo canceller reference to use the EF Bus Reference.

For systems with more than one room, you will need to use the W, X, Y, or Z sub-busses to share the echo canceller reference in your additional rooms if the EF Bus Reference has already been assigned to the EF Bus.

PRESETS

After configuring your EF2280, save your settings to a User Preset (PRESETS 16-47). Also, set the POWER ON PRESET to the User Preset you have saved to.

If you have multiple EF2280s in your system, save to a User Preset on each unit and set the POWER ON PRESET accordingly.

OTHER EF2280 FEATURES

For information on Macros, Logic Inputs, Logic Outputs, Input Filters and Output Filters, please refer to the Conference Composer User Guide.

LCD MENU STRUCTURE

LCD Menu Tree

The EF2280 LCD menu structure is made up of seven menu trees: SYSTEM, INPUTS, OUTPUTS, AUTOMIXER, MATRIX, PARAMETRIC EQ, and PRESETS. Each menu tree is organized by levels and branches into multiple subcategories. The branches end with an adjustable parameter or value.

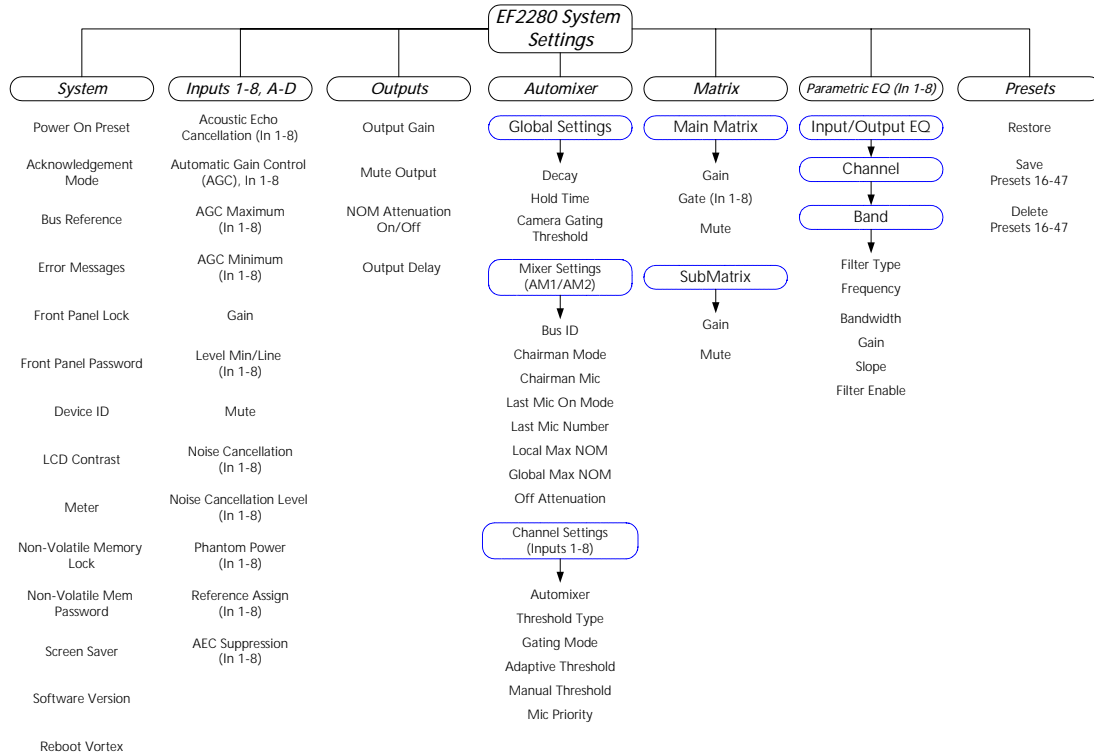

Figure 18. LCD Menu Tree.

| DOWN | UP | ENTER | ESC | HOME |
|---|---|---|---|---|
| Scrolls backward through menu items at particular level or decreases the value of a parameter | Scrolls forward through menu items at particular level or increases the value of a parameter. | Enters the menu and allows you to select and change parameter values. | Returns to the top of the next highest level of menus | Returns to the top of the menu structure. |

Table 2: Summary of button functions on the EF2280.

The EF2280 has five menu buttons on the front panel for navigation in the menu tree. Press the HOME button from anywhere in the menu tree to return to the top of the menu. The ENTER button enters the menu and the ESC button returns to the next highest level of menus. To scroll back through menu items at a particular level, use the

DOWN button. To scroll forward through menu items at a particular level, use the UP button.

To adjust a parameter, first locate the parameter by scrolling to the appropriate menu (with combinations of the UP/DOWN and ENTER buttons). The display will show the parameter field and the parameter value. To change the parameter, the parameter must be flashing. To make the parameter flash (assuming the front panel is not locked) press ENTER. Once the parameter is flashing, use the UP and DOWN buttons to adjust the parameter value. The parameter is instantly updated while it is being adjusted — you should hear changes as the parameter is changing. RS-232 control strings are also sent via the RS-232 port so your remote control device is instantaneously updated as well. Press ENTER to select and store the parameter value or press ESC to cancel the selected value and return to the old value. Pressing HOME has the effect of pressing ESC then HOME, so the selected value will be cancelled and the menu will return to the top of the menu tree.

Parameters that toggle or select among a list of options will wrap around when you reach the end, but parameters that adjust numeric values will not wrap around once the maximum or minimum value is reached. While adjusting a parameter, the UP/DOWN button must be held down briefly before the repeat rate increases.

System Overview

Table 3 below shows a summary of EF2280 parameters and their ranges..

| EF2280 Software Control Parameters Worksheet | | | | | | | | | | | | | |
|--|---------------------------------|------------|------------|----------|----------|----------|----------|----------|----------|----------|----------|----------|----------|
| System Parameters | | | | | | | | | | | | | |
| Program Parameter | Options | | | | | | | | | | | | |
| Preset | 0-47 | | | | | | | | | | | | |
| Macros | 0-255 | | | | | | | | | | | | |
| Set Passcode | Passcode | | | | | | | | | | | | |
| Device ID | 0-7 | | | | | | | | | | | | |
| Unit ID Number | Factory programmed | | | | | | | | | | | | |
| Auto Mix Parameters | | | | | | | | | | | | | |
| | | AM1 | AM2 | | | | | | | | | | |
| Program Parameter | Options | | | | | | | | | | | | |
| Chairman Mic | On, Off | | | | | | | | | | | | |
| Decay | 0 to 5000 (1000) | | | | | | | | | | | | |
| Hold Time | 1 to 5000 (500) | | | | | | | | | | | | |
| Last Mic On Mode | Last On, Off, or Any microphone | | | | | | | | | | | | |
| Max NOM per Automixer | Off, 1 to 8, (8) | | | | | | | | | | | | |
| Off Attenuation | 0 to -100 dB (-15) | | | | | | | | | | | | |
| Input Channels | | | | | | | | | | | | | |
| | | 1 | 2 | 3 | 4 | 5 | 6 | 7 | 8 | A | B | C | D |
| Program Parameter | Options | | | | | | | | | | | | |
| Acoustic Echo Cancellation | On, Off | | | | | | | | | | | | |
| Automatic Gain Control (AGC) | On, Off | | | | | | | | | | | | |
| Automixer | 1 or 2, Off | | | | | | | | | | | | |
| Echo Canceller Reference | Ref1, Ref2, External Bus Ref | | | | | | | | | | | | |
| Filtering | On, Off | | | | | | | | | | | | |
| Gain - mic level, Inputs 1-8 | 0 to 30 dB, 15 dB | | | | | | | | | | | | |
| Gain - line level, Inputs 1-8 | 0 to 30 dB, 0 dB | | | | | | | | | | | | |
| Gain, Inputs A-D | 0 to 20 dB, 0 dB | | | | | | | | | | | | |
| Gate Priority | 1 to 4 (1) | | | | | | | | | | | | |
| Gate Ratio | 0 to 100 dB (10) | | | | | | | | | | | | |
| Gate Threshold | Manual, Adaptive | | | | | | | | | | | | |
| Gating | Auto, Forced On/Off | | | | | | | | | | | | |
| Manual Threshold | 0 to 100 (60) | | | | | | | | | | | | |
| Mute | On, Off | | | | | | | | | | | | |
| Noise Cancellation | Off, 6dB, 10dB | | | | | | | | | | | | |
| Output Channels | | | | | | | | | | | | | |
| | | 1 | 2 | 3 | 4 | 5 | 6 | 7 | 8 | A | B | C | D |
| Program Parameter | Options | | | | | | | | | | | | |
| Mute | On, Off | | | | | | | | | | | | |
| Gain | -100 to 20 dB, 0 dB | | | | | | | | | | | | |
| NOM Attenuation, Outputs 1-8 | On, Off | | | | | | | | | | | | |
| NOM Attenuation, Outputs A-D | On, Off | | | | | | | | | | | | |

Table 3: EF2280 Parameters Worksheet

Trademark Notice: Vortex® is a registered trademark of Polycom, Inc.

SYSTEM MENU

| | |
|--|---|
| <div style="border: 1px solid black; border-radius: 15px; padding: 2px 10px; display: inline-block; margin-bottom: 10px;"><i>System</i></div> <ul style="list-style-type: none"> Power On Preset Acknowledgement Mode Bus Reference Error Messages Front Panel Lock Front Panel Password Device ID LCD Contrast Meter Non-Volatile Memory Lock Non-Volatile Mem Password Screen Saver Software Version Reboot Vortex | <p>The SYSTEM menu contains POWER ON PRESET, ACKNOWLEDGEMENT MODE, BUS REFERENCE, ERROR MESSAGES, FRONT PANEL LOCK, FRONT PANEL PASSWORD, DEVICE ID, LCD CONTRAST, METER, NON-VOLATILE MEMORY LOCK, NON-VOLATILE MEMORY PASSWORD, SCREEN SAVER, SOFTWARE VERSION, and REBOOT EF2280 configurations.</p> <p>Power On Preset. Choose the EF2280 Preset for power up.</p> <p>Acknowledgement Mode. This command controls whether or not status messages are sent.</p> <p>EF Bus Reference. This designates which EF2280 device, when multiple devices are linked together, will put one of their echo canceller references on the EF bus to be used as the EF bus reference.</p> <p>Error Messages. Turns error messages On or Off.</p> <p>Front Panel Lock. Locks or unlocks the front panel. When the front panel is locked, you can see the parameters but you cannot change them.</p> <p>The default passcode is <code>aspi</code> (case is important).</p> <p>Front Panel Passcode. Once the device has been unlocked, the passcode may be changed. At the FRONT PANEL PASSCODE menu, press ENTER and then enter a passcode and press ENTER until you reach the end of the screen.</p> <p>Device ID. Selects the Device ID of the unit.</p> <p>LCD Contrast. Controls the contrast level of the front panel liquid crystal display (LCD). Higher numbers result in darker characters on the display, lower numbers result in lighter characters.</p> <p>Meter. Selects which signal is displayed on the front panel LED meter.</p> <p>Non-Volatile Memory Lock. Controls the non-volatile lock feature. When the non-volatile memory is locked, you can query the settings but will get an error if you try to change them.</p> <p>Non-Volatile Memory Password. This feature sets or queries the non-volatile lock password. This password is used in conjunction with NON-VOLATILE MEMORY LOCK. The default password is <code>aspi</code> (case is important).</p> <p>Screen Saver. Enables or disables the screen saver on the LCD panel. You can also set the idle time.</p> <p>Software Version. Queries the software version.</p> <p>Reboot EF2280. Cycles power on the EF2280.</p> |
|--|---|

Figure 19. EF2280 System submenu

INPUTS

- Inputs 1-8, A-D*
- Acoustic Echo Cancellation (In 1-8)
- Automatic Gain Control (AGC), In 1-8
- AGC Maximum (In 1-8)
- AGC Minimum (In 1-8)
- Gain
- Level Min/Line (In 1-8)
- Mute
- Noise Cancellation (In 1-8)
- Noise Cancellation Level (In 1-8)
- Phantom Power (In 1-8)
- Reference Assign (In 1-8)
- AEC Suppression (In 1-8)

The input menu allows the user to adjust functions related to the input signals to the EF2280. This menu contains ACOUSTIC ECHO CANCELLATION, AUTOMATIC GAIN CONTROL, AGC MAXIMUM, AGC MINIMUM, GAIN ADJUST, LEVEL MIC/LINE, MUTE, NOISE CANCELLATION, NOISE CANCELLATION LEVEL, PHANTOM POWER, REFERENCE ASSIGN, and AEC SUPPRESSION. The menu is organized around the Inputs (1-8) and (A-D), so that you first select an input and then select settings for that input. You can also choose to apply the settings to all Inputs, Inputs 1-8, or Inputs A-D.

Acoustic Echo Cancellation. This allows you to enable or disable the acoustic echo canceller on a particular channel. The default is On.

Automatic Gain Control. This enables automatic gain control (AGC) on Inputs 1-8. The default is On.

AGC Max. Sets the maximum gain value that the AGC can apply.

AGC Min. Sets the minimum gain value that the AGC can apply.

Gain. This parameter adjusts the gain level of the 12 inputs. This is normally configured during the calibration process. **The default setting is 15 dB for microphone signals and 0 dBu for line level signals.** See “Level” above for setting mic/line level for Inputs 1-8. The LEVEL INDICATOR on the front panel automatically reflects the level of the channel whose gain is being adjusted.

Figure 21 below shows the gain adjust on Inputs 1-8 and A-D and the matrix cross-points.

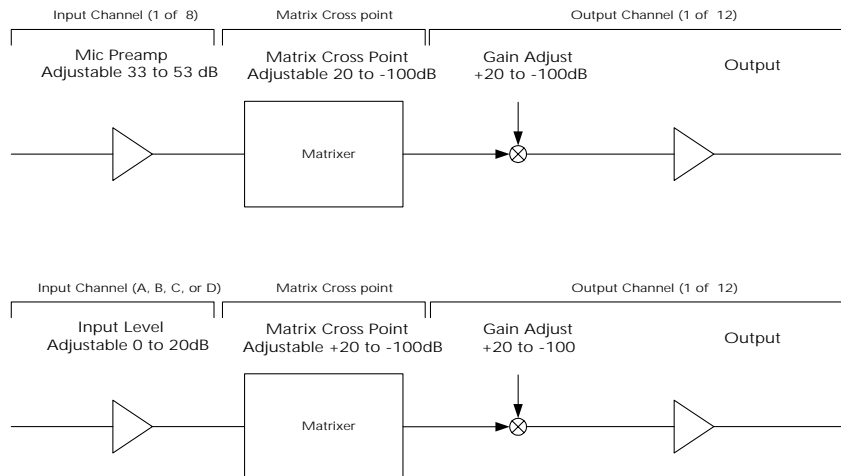

Figure 21. Gain adjust and matrix crosspoints of Inputs 1-8 and A-D.

Level. Use this parameter to select mic or line level on Inputs 1-8.

Mute. This selects which input channel (1-8, A-D) or the W, X, Y, or Z input is muted. The default is not muted.

Noise Cancellation (Inputs 1-8). This allows you to select the level of noise

cancellation. The default is 10 dB.

Noise Cancellation Level (Inputs 1-8). Selects the amount of noise cancellation. This ranges from 0 to 15 dB.

Phantom Power. Use this parameter to turn phantom power On or Off for inputs 1-8.

Echo Canceller Reference. This parameter decides which reference is associated with which zone. Choose between REF1, REF2, or the external bus reference.

AEC Suppression. Sets the amount of double talk suppression used in the AEC. The values correspond to the following settings: 1 = No Suppression, 2 = Light Suppression, 3 = Heavy Suppression, 4 = Half-Duplex.

OUTPUTS

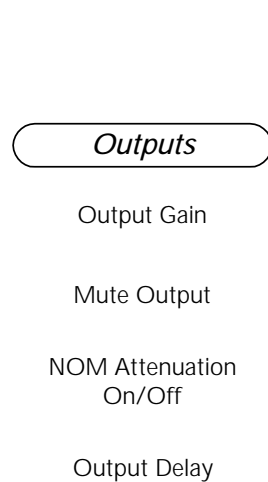

Figure 22. EF2280 Outputs submenu

The OUTPUT menu contains GAIN, NOM ACTIVE, and MUTE. As with the INPUT menus, this is done on a per channel basis including the W, X, Y, and Z busses.

Output Gain. Choose the gain applied to each output signal using this parameter. **The default setting is 0 dBu.** Though the EF2280 allows for positive output gain, you should always try to adjust input gains to a good level so that the output gain is 0 dB. If you find that you need a positive output gain from the EF2280, first check your input gain to make sure you are getting a good level (around 0dB). Keep the output gain at around 0 dBu. Then, for the best gain structure, use your amplifier to raise the volume in your system.

Mute Output. Use this to mute or unmute each Output.

NOM Active. This allows you to select whether the NOM attenuator is active for a particular output channel (Outputs 1-8, A-D). The NOM attenuator will attenuate the output signal by $10 \cdot \log_{10}(\text{NOM})$ where NOM is the number of open microphones in that particular output channel. NOM is calculated based on the number of open microphones for each signal that is in the output, including the W or X bus which carry NOM information. This option is not valid on Outputs W, X, Y, Z, or the EF Bus reference (you cannot apply NOM attenuation to these busses).

Output Delay. This allows you to add delay to the output. The default value is 0. The range of values is 0 to 340.0 ms in 0.1 ms increments.

AUTOMIXER MENU

Automixer

Global Settings

Mixer Settings

Channel Settings

Figure 23. EF2280 Automixer submenu

These parameters configure how the EF2280 automatic microphone mixer operates. Parameters include the following: DECAY TIME, HOLD TIME, CAMERA GATING THRESHOLD, BUS ID, CHAIRMAN MODE, CHAIRMAN MIC, LAST MIC ON MODE, LAST MIC NUMBER, LOCAL MAX NOM, GLOBAL MAX NOM, OFF ATTENUATION, AUTOMIXER, THRESHOLD TYPE, GATING MODE, GATE RATIO, MANUAL THRESHOLD, and MIC PRIORITY.

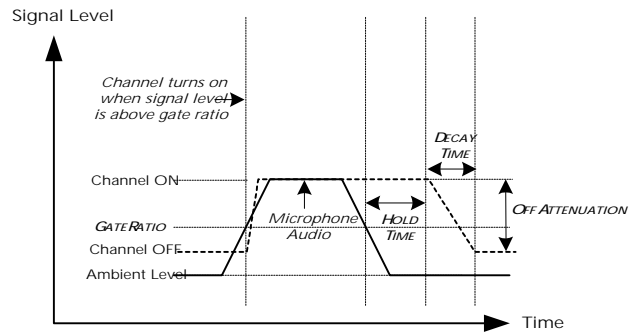

Figure 24. Automixer parameters.

Global Settings.

Decay Time. Decay time is the amount of time the microphone audio takes to ramp down to the Off Attenuation level after Hold Time. Decay Time values range from 0 to 5000 msec. The default value is 1000 msec.

Hold Time. This is the amount of time the microphone stays On after the energy in the channel drops below the gating threshold. The default value is 500 msec. The range is 1 to 5000 msec. Microphone channels gating On and Off too frequently during short pauses in speech might be the result of setting the Hold Time too low while too many microphones gating on at the same time may be the result of Hold Time values that are too high.

Camera Gating Threshold. Specifies the hold time for camera gating information.

Automixer

Global Settings

Decay

Hold Time

Camera Gating
Threshold

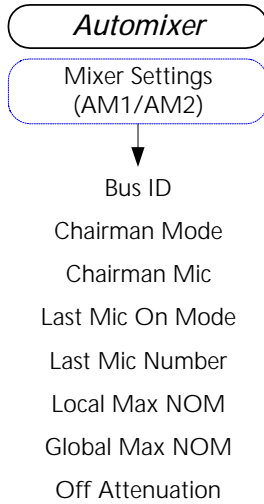

Mixer Settings.

Bus ID. This command is used to assign one of the two internal automixers to one of the EF Bus automixer groups. For example, consider three EF2280s each of which has four microphones assigned to Automixer 1 and 4 microphones assigned to Automixer 2. Now, if each of these EF2280s sets their Automixer 1 to have Bus ID 5, then the three automixers (one from each EF2280) will work as a single automixer containing 12 (3 x 4) microphones. Setting Bus ID to 0 means that the automixer is not grouped on the EF Bus.

Chairman Mode. Enables or disables Chairman Mode for the specified automixer.

Chairman Mic. Sets the Chairman Microphone for the specified automixer.

Last Mic On Mode. Sets “Last Mic On” mode for the specified automixer.

Last Mic Number. Sets the microphone number that will remain on when “Last Mic On” mode is set to manual. Setting this value to 0 will cause the automixer to leave the last open microphone on. The last microphone number is specified for each automixer, but is only used in manual “Last Mic On” mode.

Local Max NOM. Sets the maximum number of open microphones (NOM) limit for the specified automixer. This NOM limit is a “local” limit, meaning that this limit applies only to the specific EF2280 that it is set on.

Global Max NOM. Sets the global maximum number of open microphones (NOM) limit for each linked automixer. The maximum value for this command is 64. This NOM limit is a “global” limit, meaning that this limit applies to all linked automixers with the same Bus ID.

Off Attenuation. Sets the Off Attenuation (in dB) for the specified automixer. Setting this value to 18 would result in the microphone signals being attenuated by 18 dB when gated off. This value is set independently for each of the automixers.

Channel Settings.

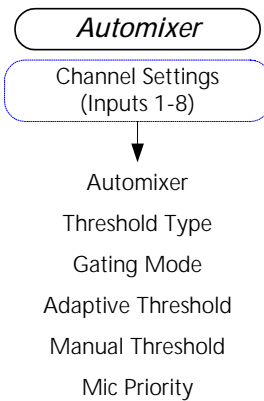

Automixer (Inputs 1-8). This allows you to select which automatic microphone mixer (1 or 2) a particular microphone channel is assigned to. A microphone may only be assigned to automatic mixer 1, automatic mixer 2, or neither (but not both).

Threshold Type. Sets automatic (also referred to as adaptive) or manual automatic gating thresholds per input.

Gating Mode. Sets the automixer gating control mode for specified input channel. The possible modes are Normal Gating, Microphone Forced On, or Microphone Forced Off.

Adaptive Threshold. This allows you to determine when to gate a microphone on based on an estimate of the background noise level. The default value is to gate a channel on if it is more than 10 dB louder than the background noise level. Values range from 0 to 100 dB. To set the gate ratio, scroll through the gate ratio range and select the desired gate ratio by pressing ENTER.

Manual Threshold. Sets the automixer gating threshold for the specified input channel. This value is only used if the input set to Manual Gating via the THRESHOLD TYPE option.

Microphone Priority. The priority of each microphone can be assigned a value ranging from 1 to 4. Priority 1 microphones have priority over priority 4 microphones for gating. The default is to have all microphones set to priority 1. If Chairman Mode is enabled, all microphones including ones with priority of 1 will be gated off when the Chairman mic gates on.

MATRIX MENU

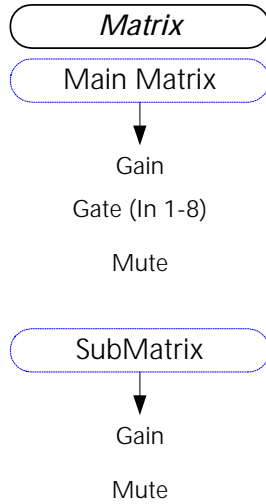

Figure 25. EF2280
Matrix submenu

The MATRIX contains commands for assigning input signals to output signals with appropriate gains applied or mutes applied. It also allows for Gating to be turned on for Inputs 1-8. This menu can apply gains to both the MAIN MATRIX and the SUBMATRIX.

Crosspoint Gains. Assign input signals to output signals with appropriate gains applied.

Gate. Applies gating from Inputs 1-8 to an Output.

Mute. Applies mute to the crosspoint.

PARAMETRIC EQ MENU

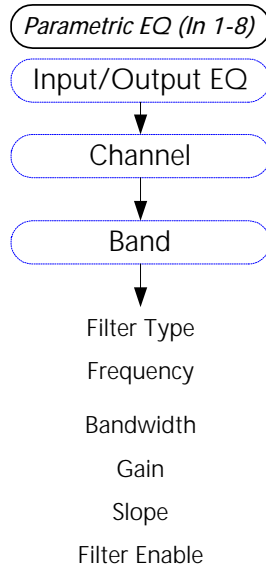

Figure 26. EF2280
Parametric EQ sub-
menu

The input equalizer is comprised of up to 5 bands of filtering. The whole group of filters for the channel can also be enabled/disabled without losing the settings for each band. For each band, you first select the type of filter from the following: Parametric/Peaking, High Shelf, Low Shelf, Lowpass, or Highpass.

Parametric/Peaking.

- Center Frequency: in Hz, between 20 Hz and 20,000 Hz in 1 Hz steps.
- Bandwidth: in octaves, between 0.05 and 2 octaves in 0.05 octave steps.
- Gain: in dB, between -20 and +20 in 1 dB steps.

High Shelf.

- Center Frequency: in Hz, between 20 Hz and 20,000 Hz in 1 Hz steps.
- Bandwidth: in dB/octave, between 1 and 24 dB/octave, but is always less than or equal to 1.2 x Gain.
- Gain: in dB between -20 and +20 in 1 dB steps.

Low Shelf.

- Center Frequency: in Hz, between 20 Hz and 20,000 Hz in 1 Hz steps.
- Bandwidth: in dB/octave, between 1 and 24 dB/octave, but is always less than or equal to 1.2 x Gain.
- Gain: in dB between -20 and +20 in 1 dB steps.

Lowpass.

- Cutoff Frequency: in Hz, between 20 Hz and 20,000 Hz in 1 Hz steps.

Highpass.

- Cutoff Frequency: in Hz, between 20 Hz and 20,000 Hz in 1 Hz steps.

Center frequency on Parametric/Peaking is the point with the most (or least) gain. Bandwidth is the width halfway up the peak (so if the peak is 10 dB, it is the width between the points where the gain is 5 dB).

Center frequency on shelving filters is the frequency where it crosses the point halfway between 0 dB and the gain of the filter, halfway up the slope.

TROUBLESHOOTING

AUTOMATIC MICROPHONE MIXER

No microphones are gating

- Check if the microphones are muted.
- Are microphones part of one of the 2 automixers?

Some microphones are not gating

- Check if the microphones are assigned to an automixer.
- Check if the microphones are muted.
- Check microphone levels. Are microphones set to the appropriate mic or line level? Is phantom power on where needed?
- The Hold Time may be too low. Microphone channels gating On and Off too frequently during short pauses in speech might be the result of setting the Hold Time too low.
- Check Gating settings. Are microphones Forced Off?
- Is Chairman Mode on? If you have assigned a Chairman Mic, all other microphones will gate Off once this microphone gates on.
- Check Gating Priority. If your inputs have a Gating Priority of 4, the microphones may not gate as frequently.
- Check Maximum Number of Open Microphones. This parameter sets the number of open microphones allowed at any time. If this parameter is set too low, the microphones may not gate as often as you wish.
- Adjust the Gate Ratio if the Gate Threshold is set to Adaptive or adjust the Manual Threshold if the Gate Threshold is set to Manual. For Adaptive Gate Threshold, set the Gate Ratio lower so that the microphone will gate On when lower level signals are present at the microphone. For Manual Gate Threshold, set the Manual Threshold to a lower absolute threshold.

Too many microphones are gating

- The Hold Time might be too high. Too many microphones gating on at the same time may be the result of Hold Time values that are too high.
- Assign a Chairman Mic. This will cause all other microphones to gate Off once this microphone gates on and will prevent too many microphones from gating.
- Set Gating Priority so that not all microphones have the same priority. The default value for each input is a Gating Priority of 1, which is the highest priority.
- Adjust the Gate Ratio if the Gate Threshold is set to Adaptive or adjust the Manual Threshold if the Gate Threshold is set to Manual. For Adaptive Gate Threshold, set the Gate Ratio higher so that the microphone will gate when only louder signals are present at the microphone. For Manual Gate Threshold, set the Manual Threshold to a higher absolute threshold.
- Using the Adaptive Gate Threshold is recommended for more accurate gating.

MATRIX MIXER

Don't hear output

- Make sure the output is not muted.
- Check that the input you're expecting to hear is included in the output that you're listening to.

ECHO CANCELLER REFERENCE

Room Audio Sounds Choppy

If you hear the local room's audio from the loudspeakers and it sounds choppy, you may have included the room's microphones in the echo canceller reference. The echo canceller reference should NOT include the local room's microphones -- it should only contain the remote end's audio and program audio. You can still add the local room's microphones to the local output with the matrix, but do not add them to the echo canceller reference. For more specific guidelines on what to include in your echo canceller reference, see "Build Your Echo Cancellor Reference" on page 17.

RESIDUAL ECHO

You may hear residual echo if system levels are not set properly. Improper level settings anywhere in the audio path can introduce nonlinearities that hamper the operation of the EF2280. If you hear residual echo, one of the following conditions may be causing the problem.

Reverberation vs. Acoustic Echo

Do not confuse the residual echo of remote speech with the reverberation of local speech. Reverberation of local speech is caused when the speech signal arrives at the microphone via several paths (the direct path and multiple reflections from surfaces in the room). This is a local room phenomenon that gives the talker's voice a hollow or resonant sound (as heard at the remote end).

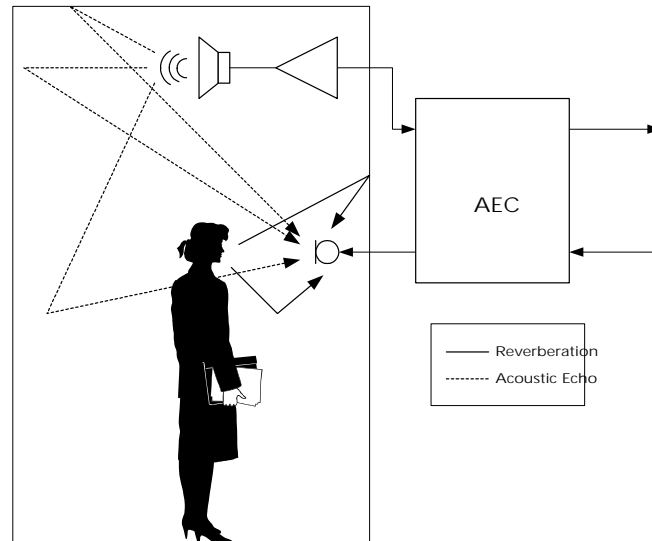

Figure 27. Reverberation vs. Acoustic Echo.

Reverberation is not an artifact of the echo canceller. It is mainly affected by the distance of the microphone from the speech source and by the resonances of the room. While reverberation can be unpleasant, it is not compensated for by the acoustic echo canceller (AEC), which only removes reflections of remote speech. If the remote end complains that they hear echo, ensure that they are referring to hearing their own voice and not echoes of local talkers.

You cannot remove the effects of reverberation by changing the EF2280's settings, but you can minimize reverberation by moving microphones closer to talkers and, if necessary, adding acoustical treatment to the room.

Finding the Source of Echo

Try muting one channel at a time to see if the echo that the remote end is hearing goes away when a particular channel is muted. If you find that the echo goes away when a particular channel is muted, the microphone may not be calibrated correctly. Check one or more of the following issues.

Room Gain

The most common cause of poor echo cancellation performance is incorrectly adjusted room gain. This may be explained as follows. The reference signal seen by the AEC is sent to a loudspeaker output, where it is amplified and sent to the room loudspeakers. The loudspeaker audio is coupled into the room microphones acoustically, through direct and reflected acoustic paths, and perhaps also through mechanical coupling. The microphone signal is then amplified and sent to the AEC as the local microphone input signal. The room gain of a microphone channel refers to the relative levels of the signal sent to the loudspeaker output (before any amplification)

and the level of this signal that is reflected as the microphone input (after microphone amplification).

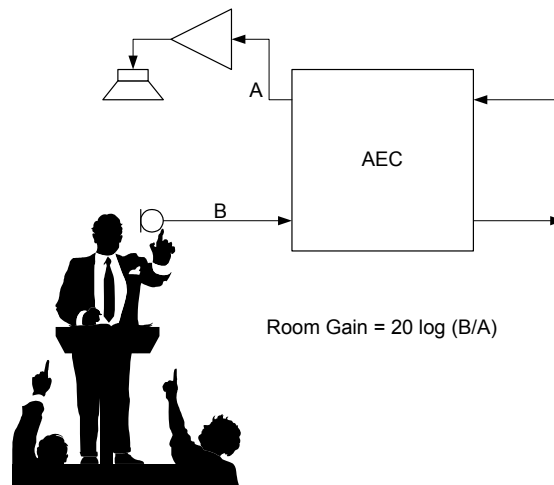

Figure 28. Room Gain.

If the electrical level of the reflected signal picked up by microphone is the same as the level of the electrical signal sent from the AEC to the loudspeaker output, the room gain of this microphone channel is said to be 0 dB. If the reflected signal picked up by the microphone is higher than the level of the signal sent to the loudspeaker output, that microphone channel has positive room gain. The more positive the room gain, the harder the AEC must work to determine which signal is an echo and which is a local speech signal.

Excessive Room Gain

Excessive room gain can be caused through a number of mechanisms:

1. The most common is excessive amplification of the remote (reference) signal at the local loudspeaker output. This may be explained as follows. If the reference signal is too low coming into the EF2280, i.e. the codec audio signal is too low, the room audio amplifier is usually used to compensate and bring the room audio to an acceptable level. For example, if the reference signal is 12 dB too low, the room audio will need to be amplified by approximately 12 dB to bring it to a reasonable listening level. This adds 12 dB to the room gain, which will most likely cause it to exceed the amplifier room gain limit (See “Verify Room Gain” on page 13). This situation can be remedied by applying enough gain to the codec, phone or program audio inputs (Inputs A-D) which will make up the Reference input signal so that the acoustic echo canceller (AEC) sees a good reference signal rather than trying to compensate at the amplifier.
2. Another common cause of room gain failure is excessive microphone amplification. For example, if a microphone is "hot" by 6 dB, then the reflections of the loudspeaker output signal which are picked up by the microphone will be amplified by 6 dB more than necessary. This adds 6 dB to the room gain, which may be sufficient to cause room gain problems. This situation could easily arise if, for example, the conferencing equipment is set up so that participants are too far from the microphone. In such a situation, after correct microphone setup the local microphone audio level may be too low because of the distance from the

talker to the microphone. The microphone audio will most likely also be muddy and reverberant. The installer or user may try to solve these microphone audio quality problems by turning up the microphone amplification, thus adding to the room gain. This problem can be remedied by proper microphone selection (pickup pattern, directionality) and placement, coupled with proper microphone input calibration.

3. A third common cause of room gain problems is excessive coupling between loudspeaker audio and microphones. This can be addressed by reducing the microphone coupling, either by positioning microphones so that their pickup patterns are biased away from the loudspeaker audio (and direct reflections of loudspeaker audio), repositioning loudspeakers, or reducing the loudspeaker amplification.

In summary, any amplification applied between the reference input and the microphone inputs can add to room gain problems. To avoid problems, ensure that the Reference input signal is not too low, and the microphone input signals are not too high. Run the built-in EF2280 Room Gain test to verify that you do not have room gain problems (See “Verify Room Gain” on page 13).

| COMMON CAUSES OF EXCESSIVE ROOM GAIN | REMEDY |
|--|---|
| Excessive remote (reference) input amplification | Apply enough gain to the codec, phone or program audio inputs which will make up the Reference input signal. |
| Excessive microphone amplification | Select proper microphones for talker distance according to pickup pattern and directionality and properly calibrate mic inputs. |
| Excessive coupling between loudspeaker audio and microphones | Reduce mic coupling by repositioning mics or loudspeakers, or by reducing loudspeaker amplification. |

Table 4: Summary of Excessive Room Gain.

In-Conference Quick Check

If you experience residual echo problems during a conference, you can quickly check that the reference and microphone levels are calibrated and not causing room gain problems by using the Room Gain parameter (See “Verify Room Gain” on page 13).

If this excessive coupling activity level is evident on only one microphone input channel, that microphone channel should either be redirected to reduce coupling to loudspeaker audio, or recalibrated as it will need to be turned down. If the excessive coupling activity is observed on all (or most) microphone channels, then this indicates either that the room audio is too loud or the reference signal may need to be recalibrated (this will be indicated by observing low activity levels on the SIGNAL LEVEL METER).

Excessive Microphone Amplification

For the EF2280 to adapt effectively, saturation (overload or clipping) must not occur at the A/D converter supplying the microphone input. Saturation introduces nonlinear signal distortions into what the AEC expects is a linearly echoed version of the remote speech.

Nonlinear distortion causes a degradation or divergence of the AEC's internal model of the room acoustics. In this situation, the EF2280 cannot effectively cancel room echoes and a substantial amount of echo may be heard by the remote party.

Excessive microphone amplification also increases room gain (See "Excessive Room Gain" on page 39.). You can check for excessive microphone amplification by observing the front panel LEVEL INDICATOR during a normal conference. The first yellow LED should illuminate frequently. If the second yellow LED is illuminated constantly during normal speech or if the red LED illuminates or even flickers, reduce the microphone input level.

Note. Before you readjust the microphone input levels, check to make sure you are looking at the correct channel on the LEVEL INDICATOR.

Note. If you adjust the MIC/LINE INPUT level, you will affect the room gain. Check to make sure that the room gain limit is not exceeded. See "Verify Room Gain" on page 13.

Insufficient Microphone Amplification

Grossly insufficient microphone gain degrades EF2280 performance and weakens the out-bound speech power level. This has the effect of reducing the signal-to-noise ratio of the microphone signal, which is analogous to raising the background noise level in the room. Because this noise is uncorrelated with the echoes within the room, the EF2280's ability to adapt and cancel echoes will be less than optimal.

A second effect of insufficient microphone gain is that the power of the microphone input signal may be substantially lower than that of the remote input signal. This reduces the ability of the decision logic to determine whether the AEC should be in transmit, receive, or double-talk mode. This effect may reduce the effectiveness of the EF2280 in canceling echoes.

You can check for insufficient microphone amplification by observing the front panel LEVEL INDICATOR during normal conferencing conversation. The first yellow LED should illuminate frequently. If the LEVEL INDICATOR never illuminates beyond one or two green LEDs during normal speech, increase the microphone's input level.

Note. Before you readjust the microphone input levels, check to make sure you are looking at the correct channel on the LEVEL INDICATOR.

Note. If you adjust the MIC/LINE INPUT level, you will affect the room gain. Check to make sure that the room gain limit is not exceeded. See "Room Gain" on page 38.

Nonlinearity

Overdriving the loudspeaker or inserting a dynamics processor before the EF2280 may distort the signal that the microphones see causing ineffective AEC operation. The EF2280 relies on the linearity of the acoustic feedback path — D/A, amplifier, loudspeaker, microphone, and A/D — to cancel acoustic echoes. If you overdrive the loudspeaker or insert a dynamics processor before the echo canceller, the acoustic reflections picked up by the microphone do not match the signal fed to the loudspeaker. They are distorted copies of this signal. The EF2280 cannot effectively cancel this distorted signal.

If you suspect the loudspeaker is introducing nonlinearities into the room acoustic path, take these steps to minimize its influence on the echo canceller.

- Keep the loudspeaker's volume level at less than three-eighths of full scale. If higher volume is required, the EF2280 should operate effectively at volume settings of up to 50 percent of full scale. At more than 50 percent, most audio systems and loudspeakers introduce significant nonlinearities. The EF2280 may not adapt under these conditions, and echoes may be heard.
- If the loudspeaker has a bass control, lower it. Excessive bass can cause a *boomy* effect that is nonlinear. In addition, excessive bass may cause substantial mechanical coupling to the microphone through vibrations induced in the housings and support structures.
- Increase the separation distance between microphones and the loudspeaker. The EF2280 handles up to 10 dB of room gain between the loudspeaker and the microphone. You may be exceeding this limit if the loudspeaker is pointed directly at the microphones or if the loudspeaker volume is excessive (loudspeaker placement is not critical, but it should not be pointed directly at the microphones).

CONTACTING TECHNICAL SUPPORT

If these troubleshooting guidelines don't resolve the problem you are experiencing with the EF2280, please check our web site (<http://www.aspi.com>) for the most current technical support information (go to Technical Resources, then to Technical Support). If you have further questions, please contact us at:

Applications Engineering
Polycom Installed Voice Business Group
1720 Peachtree Street NW Suite 220
Atlanta, GA 30309-2439

Phone: (800) 932-2774
Fax: (404) 892-2512
Email: vortex@polycom.com

Before contacting us, please review the warranty and repair policy on page 52.

Trademark Notice: Vortex[®] is a registered trademark of Polycom, Inc. All Rights Reserved.

TECHNICAL SPECIFICATIONS

MECHANICAL SPECIFICATIONS

| | |
|------------|---|
| Dimensions | 19" (483 mm) W x 9.6" (244 mm) L x 1.75" (45 mm) H (full rack unit) |
| Weight | 4 lb. (1.8 kg) dry 5.5 lb. (2.5 kg) shipping |
| Connectors | Audio: Mini (3.5mm) quick connect terminal blocks RS-232: DB9F EF Bus In/Out: RJ45 ASPI Bus: RJ45 Control/Status: DB25F |

ELECTRICAL SPECIFICATIONS

| | |
|-------------------|---------------------------|
| Power | 110 - 240 VAC; 47-63 Hz |
| Power Consumption | 25 W |
| Phantom Power | 24 V, software selectable |

AUDIO I/O

| | |
|------------------------|---|
| Microphone Input Level | -30 dBu to 0 dBu/-66 dBu to -33 dBu, nominal; software selectable |
| Line Input Level | -20 dBu to 0 dBu, nominal; software selectable |
| Line Output Level | -20 dBu to 0 dBu, nominal; software selectable |
| Input Impedance | 10 kOhms |
| Output Impedance | 50 Ohms (drives 600 Ohms) |
| Headroom | 20 dB, nominal |

PERFORMANCE SPECIFICATIONS

| | |
|---------------------------------|------------------------------------|
| Frequency Response | 20 Hz to 22 kHz |
| Acoustic Echo Cancellation Span | 270 ms |
| Total Cancellation | > 65 dB |
| Convergence Rate | 40 dB/second |
| Noise Cancellation | 0 dB to 15 dB, software selectable |

| | |
|----------------|-----------------|
| Control Inputs | Contact closure |
| Status Outputs | 5V, 20 mA each |

COMPLIANCE

The Vortex EF2280 complies with the ITU G.167 Recommendation for AEC, FCC part 15, and CE requirements.

USA and Canada

This device complies with part 15 of the FCC Rules. Operation is subject to the following two conditions:

1. This device may not cause harmful interference, and
2. This device must accept any interference received, including interference that may cause undesired operation.

NOTE This equipment has been tested and found to comply with the limits for a Class A digital device, pursuant to part 15 of the FCC Rules. These limits are designed to provide reasonable protection against harmful interference when the equipment is operated in a commercial environment. This equipment generates, uses, and can radiate radio frequency energy and, if not installed and used in accordance with the instruction manual, may cause harmful interference to radio communications. Operation of this equipment in a residential area is likely to cause harmful interference in which case the user will be required to correct the interference at his own expense.

In accordance with part 15 of the FCC rules, the user is cautioned that any changes or modifications not expressly approved by Polycom Inc. could void the user's authority to operate the equipment.

This Class [A] digital apparatus complies with Canadian ICES-003.

Cet appareil numérique de la classe [A] est conforme à la norme NMB-003 du Canada.

CE Mark – LVD and EMC Directive

This Vortex EF2280 has been marked with the CE mark. This mark indicates compliance with EEC Directives 89/336/EEC and 73/23/EEC. A full copy of the Declaration of Conformity can be obtained from Polycom Ltd, 270 Bath Road, Slough, Berkshire, SL1 4DX, UK.

VCCI Class A

この装置は、情報処理装置等電波障害自主規制協議会（VCCI）の基準に基づくクラスA情報技術装置です。この装置を家庭環境で使用すると電波妨害を引き起こすことがあります。この場合には使用者が適切な対策を講ずるよう要求されることがあります。

*Rest of World
EMC CLASS A ITE***WARNING**

This is a Class A product. In a domestic environment this product may cause radio interference in which case the user may be required to take adequate measures.

***Installation
Instructions****

*Installation must be performed in accordance with all relevant national wiring rules.
L'Installation doit être exécutée conformément à tous les règlements nationaux applicables au filage électrique.*

***Plug acts as
Disconnect Device****

The socket outlet to which this apparatus is connected must be installed near the equipment and must always be readily accessible

CONFERENCE SYSTEM DESIGN

Good audio or video conferencing is more than acoustic echo cancellation. Before installing the EF2280, you should consider how your whole conference system will work together. The goals of conference system design are the following:

- Transmit intelligible speech
- Reproduce received speech intelligibly
- Prevent echoes
- Interface properly with transmission equipment
- High quality program audio
- Intelligible sound reinforcement (if needed)

Noise and Reverberation

Intelligibility can be affected by noise and reverberation. Noise comes from various sources such as HVAC, computers, projectors, or traffic. Some ways to improve the Signal to Noise Ratio (SNR) in your system include placing microphones closer to the talkers, using electronic noise cancellation, and applying acoustical treatments. The EF2280 is a great way to reduce noise in your system and improve the SNR. Polycom's patent pending noise cancellation algorithm, included in the EF2280, removes up to 10 dB of ambient background noise and improves perceived quality as well as intelligibility.

Reverberation in a conference system can reduce intelligibility in a room. To reduce reverberation and increase intelligibility, use directional microphone and loudspeakers, place microphones closer to the talker, and use acoustical treatment.

Consider Room Gain

When planning your conferencing system, you should also consider the room gain that will occur as a result of your microphone and loudspeaker placement. Room gain refers to the relative level of the audio going to your amplifier (remote end speech or telephone speech) and the level of this audio being picked up by the microphone. We recommend a room gain of 0 dB or less for the best results. But for difficult acoustic environments, the EF2280, as well as any of the EF products, can handle up to 10 dB room gain, which means that it offers great flexibility in your conference system design.

To help you measure room gain, the EF2280 includes a room gain detector. You should check your room gain after you have set up the EF2280.

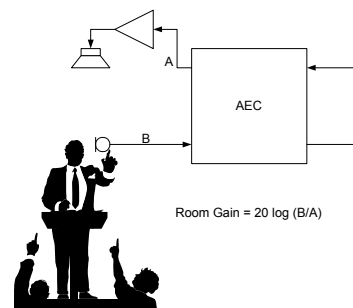

Figure 29. Room Gain.

EF2280 BLOCK DIAGRAM

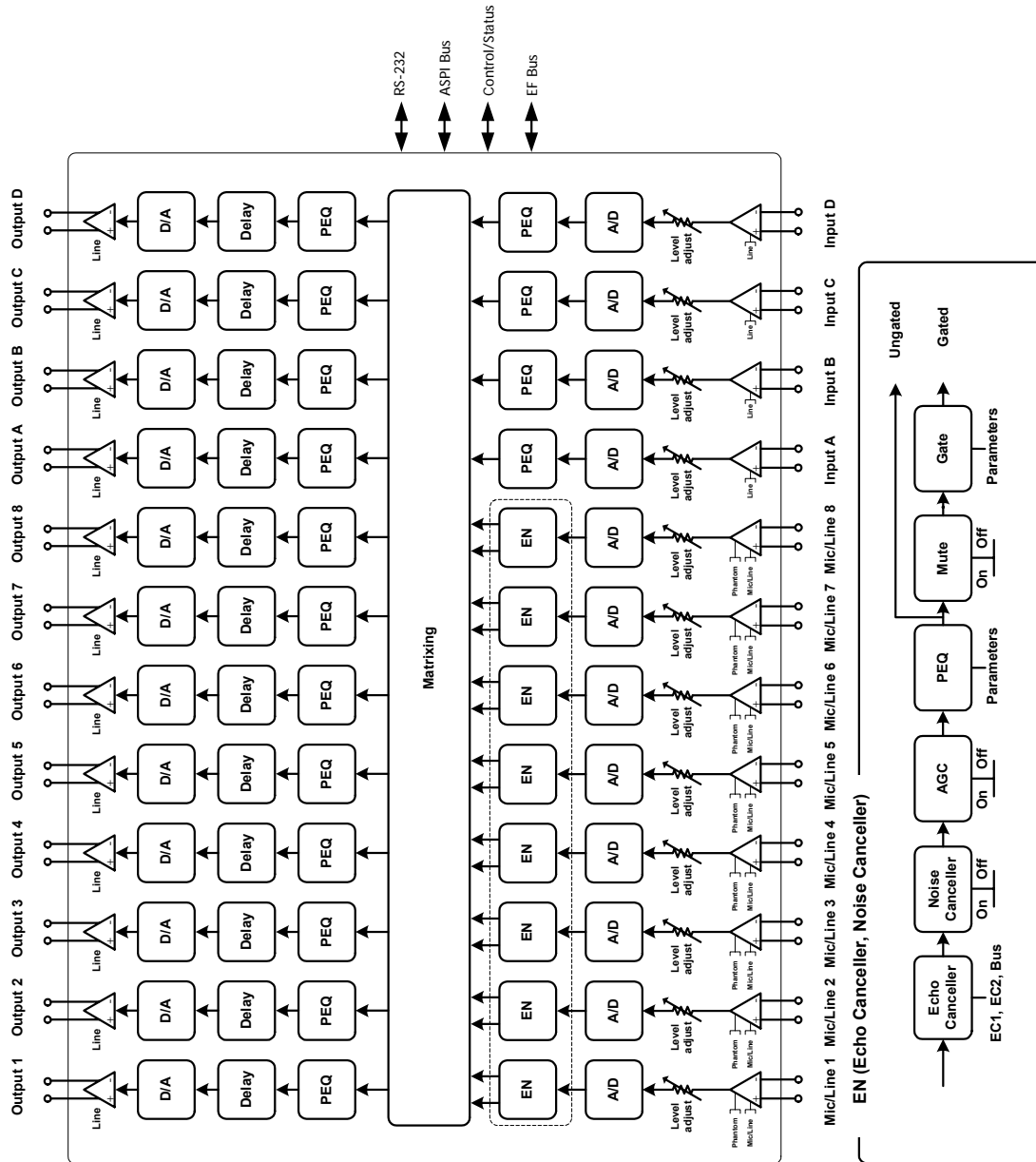
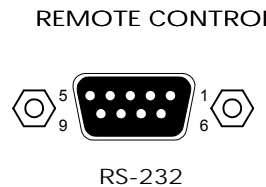
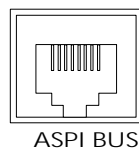
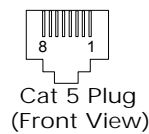
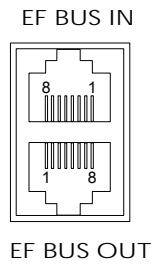

Figure 30. Inside the EF2280

Trademark Notice: Vortex[®] is a registered trademark of Polycom, Inc.

CONNECTOR PINOUTS



EF Bus

The EF Bus uses RJ45 connectors. These should be used with category five twisted-pair cable.

The total distance of the EF Bus should be less than 4 m.

The EF Bus must be connected so that the EF Bus In of one box is connected to the EF Bus Out of another. Connecting the EF Bus In to another EF Bus In (or Out to Out) will not work.

Cat-5 Plug Pinout

- 1 - White/Orange
- 2 - Orange
- 3 - White/Green
- 4 - Blue
- 5 - White/Blue
- 6 - Green
- 7 - White/Brown
- 8 - Brown

ASPI Bus

The ASPI Bus uses RJ45 connectors. These should be used with category five twisted-pair cable.

The total distance of the ASPI Bus should be less than 15 m.

RS-232 Port (9600 8-N-1)

The RS-232 port is wired as DCE. It accepts a male DB-9 connector. Only pins 2, 3, and 5 are required by the EF2280[®] but pins 7 and 8 are supported. Connect pins straight through (do not use null modem).

1 DCD; 2 TXD; 3 RXD 4 DSR; 5 ground; 6 DTR; 7 CTS; 8 RTS; 9 No connection

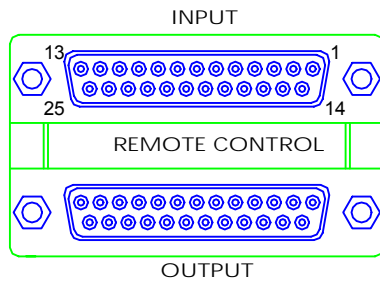

Input/Output Remote Control Port

Logic Input: Pins 1-24 are inputs 1-24, respectively. Pin 25 is ground.

Logic Output: Pins 1-20 are outputs 1-20, respectively. Pins 21-25 are ground. Each ground pin should be used with only 4 outputs. For example, outputs 1-4 could be connected to LEDs, which are connected to ground pin 1.

LEDs can be used without series resistors (we have provided series resistors in the circuitry). For best results, LEDs with $V_f=2.0$ V and $I_f=20$ mA should be used. Larger values may be used, but may result in dimmer LEDs. An LED with V_f less than 1.4 V should not be used without additional series resistance.

Power Supply Input

The power supply input accepts a 5-pin DIN male connector. Only use the power supply provided by Polycom. Use of other power supplies will void the warranty.

1 Ground; 2 Ground; 3 +5Vdc @ 3 A; 4 -15Vdc @ 0.3 A; 5 +15Vdc @ 1.2 A

+5±15% VDC

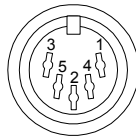

Mic/Line Inputs, Line Inputs, Line Outputs

These audio connectors accept a mini (3.5 mm) 3 conductor terminal block (provided). See Note below for manufacturer information.

From left to right the conductors are positive signal, negative signal, and shield ground.

Note *The information below lists manufacturer information for the Phoenix connector that is compatible with the parts we use:*

Manufacturer: Phoenix Contact
 Description: Mini-COMBICON 3-position plug, 3.5 mm pitch
 Type Number: MC 1,5/3-ST-3.5 or MC 1,5/3-ST-3,5
 Part Number: 1840379

For proper operation, a ferrite should be positioned on control and data cables.

CONNECTING UNBALANCED RCA TO BALANCED MINI PHOENIX

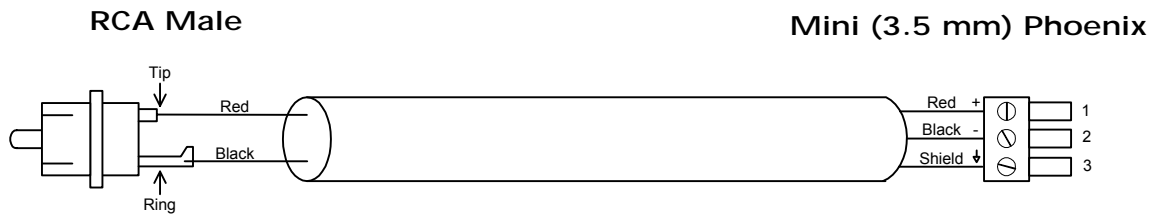

Figure 31. Cable construction for connecting unbalanced RCA to balanced mini Phoenix (3 conductor terminal block).

1. Connect RCA Tip to Phoenix pin 1.
2. Connect RCA Ring to Phoenix pin 2.
3. Connect Phoenix pin 3 to Shield, and leave Shield floating on RCA end.

Caution! Do NOT connect the shield at both ends.

Caution! On the EF2280, Phoenix pin 3 is connected to chassis ground. Under no circumstances should Phoenix pin 3 be connected to pin 1 or to pin 2. Doing so will add noise to the audio signal.

MAKING AN EF BUS TERMINATOR

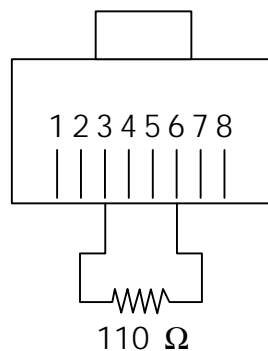

Figure 32. The EF2280 terminator

Instructions

To make a EF2280 terminator, use an RJ45 connector. Connect pin 3 to pin 6 with an 110 Ohm resistor.

ADDITIONAL NOTES

- Caution!** *Failure to use all four screws to attach the EF2280 to the rack may result in uneven loading and cause a safety hazard.*
- Caution!** *Ensure that the power supply is securely located such that it cannot become dislodged and fall. Such a fall could cause personal injury or equipment failure.*
- Caution!** *When mounting a EF2280 in a rack, consideration should be given to airflow and operating ambient temperatures inside the rack. To ensure safe operation of the EF2280, ambient operating temperatures inside the rack should not exceed 40 degrees Celsius. Allow 2 inches (51mm) of open space in front of the EF2280, 2 inches (51mm) on either side, and 4 inches (102 mm) behind the unit for proper ventilation. Equipment should not be installed in the rack in such a way as to interfere with the ventilation of the EF2280.*
- Caution!** *Consideration should be given to the connection of the equipment to the supply circuit and the effect that overloading of circuits could have an overcurrent protection and supply wiring. Appropriate consideration of equipment nameplate ratings should be used when addressing this concern.*
- Caution!** *Reliable earthing of rack-mounted equipment should be maintained. Particular attention should be given to supply connections other than direct connection to the Branch (use of power strips).*

WARRANTY INFORMATION

| | |
|------------------------------|--|
| <i>What is covered</i> | Any defect in materials or workmanship. |
| <i>For how long</i> | Two years. |
| <i>What we will do</i> | <p>If your Polycom EF2280 product is defective and returned within two years of the date of purchase, we will repair or, at our option, replace it at no charge to you.</p> <p>If we repair your Polycom EF2280 product, we may use new or reconditioned replacement parts. If we choose to replace your Polycom EF2280 product, we may replace it with a new or reconditioned one of the same or similar design. The repair or replacement is warranted for either (a) 90 days or (b) the remainder of the original two-year warranty period, whichever is longer.</p> |
| <i>Limitations</i> | <p>Polycom shall not be responsible for special, incidental, indirect, or consequential damages resulting from any breach of warranty, or under any other legal theory, including but not limited to loss of profits, downtime, goodwill, damage to or replacement of equipment and property, and any cost of recovering, reprogramming, or reproducing any program or data stored in or used with Polycom EF2280 products.</p> <p>Some states do not allow limitations on how long an implied warranty lasts, or the exclusion of incidental or consequential damages, so the above exclusions or limitations may not apply to you.</p> |
| <i>What we ask you to do</i> | <p>To obtain warranty service for your Polycom EF2280 product, call us at (800) 932-2774 or fax us at (404) 892-2512 and we will issue a Return Material Authorization number (RMA#). Use the original packaging materials to return the product. Ship the product prepaid to:</p> <p style="padding-left: 40px;">Polycom Installed Voice Business Group Attention: Warranty Repair RMA# (<i>Must be on package</i>) 1720 Peachtree Street NW, Suite 220 Atlanta, Georgia 30309-2439 USA</p> |

Trademark Notice: Vortex[®] is a registered trademark of Polycom, Inc. All Rights Reserved.

Please be sure to include your name, company, address, phone number, and a description of the problem. After repairing or replacing your Polycom EF2280 product, we will ship it to you via a surface carrier of our choice at no cost to you. If you wish it shipped via a specific carrier at your cost, you must arrange it when you obtain the RMA#.

Repair or replacement of your Polycom EF2280 product is your exclusive remedy.

What this warranty does not cover

This warranty does not cover defects resulting from accidents, damage while in transit to our service location, alterations, unauthorized repair, failure to follow instructions, misuse, fire, flood, lightning, acts of God, or use in those countries where such use violates Part 779 of the Export Administration Regulations of the United States Department of Commerce.

If your Polycom EF2280 product is not covered by our warranty, call us at (800) 932-2774 or fax us at (404) 892-2512 for advice about whether we will repair your Polycom EF2280 product and for other repair information, including charges. Polycom, at its sole discretion, may replace rather than repair your Polycom EF2280 product with a new or reconditioned one of the same or similar design. The repair or replacement is warranted for 90 days.

The limited warranties and remedies set forth above are exclusive and in lieu of all other warranties, whether oral or written, express or implied. Polycom specifically disclaims any and all implied warranties, including, without limitation, the warranties of merchantability and fitness for a particular purpose.

No User Serviceable Parts

This product contains no user serviceable parts. Please contact Polycom Installed Voice Business Group for repairs. Attempts to repair this product by an unauthorized technician will void your warranty.

State Law Rights

This limited warranty gives you specific legal rights, and you may have other rights that may vary from state to state.

DEFINITION OF TERMS

| | |
|-------------------------------------|---|
| <i>Acoustic Echo</i> | Acoustic echo occurs in a conferencing or distance learning system when the remote speech played in the loudspeakers is picked up by microphones in the room and is transmitted back to the remote end. This transmitted signal is a delayed version of the original, which causes the echo. |
| <i>Acoustic Gain</i> | Acoustic gain is a term used in conjunction with sound reinforcement. It refers to how much louder the audio is with sound reinforcement compared to without sound reinforcement. |
| <i>Ambient Level</i> | The ambient level, also referred to as noise floor, is the background noise heard in a room when no one on the near or remote end is talking. |
| <i>The ASPI Bus</i> | The ASPI bus is used to link EF devices for RS-232 control using a single controller, such as a touch panel or PC. |
| <i>Automatic Gain Control (AGC)</i> | Automatic gain control increases or decreases the gain on an audio signal to an acceptable value. |
| <i>Automatic Microphone Mixer</i> | A microphone mixer that turns microphone channels on and off based on the signal level going into the microphone. |
| <i>Convergence Rate</i> | Convergence rate refers to the amount of echo a line or acoustic echo canceller can cancel per unit time, typically expressed in dB/sec. Better echo cancellers have a higher (faster) convergence rate. This term is typically used to quantify the time it takes to completely remove the echo from a conferencing system. Echo occurs due to a complete change of the acoustic environment such as the beginning of a phone call in a conference, a change of microphone-speaker placement, or speaker volume adjustment. |
| <i>Crosspoint Mix Minus Bus</i> | A mix minus bus allows each device (i.e., a EF2280 unit) to create a mix of signals without its own. Each device in the system can create four mixes (W, X, Y, and Z) and place them on the bus. Each device also can create three mixes each from the W, X, Y, and Z busses of the other devices (for a total of 12 mixes). One mix is hard-wired as a normal mix minus. That is, it is a unity gain mix of the signals from all other devices. The other two mixes can have crosspoint gains on the signals from the other devices. |

| | |
|---------------------------|--|
| <i>Echo Canceller</i> | An echo canceller estimates the echo in an audio signal by using a reference and performs processing to eliminate the echo from the signal. |
| <i>EF Bus</i> | The EF Bus is a digital bus that includes the W, X, Y, and Z audio busses as well as the echo canceller reference and remote control information. It can be used to link multiple EF2280 devices. |
| <i>Equalization</i> | Equalization is the process of adjusting frequency characteristics of an audio signal. |
| <i>Line Echo</i> | Line echo is caused by reflections of the audio signal from the telephone hybrid. The EF200 Phone Add is an example of a unit that has a line echo canceller. |
| <i>Macros</i> | An arbitrary set of commands that can be replayed. |
| <i>Matrix Mixer</i> | A matrix mixer allows you to choose which inputs are included in each output. Some matrix mixers allow you to assign crosspoint gains to the inputs. |
| <i>Noise Cancellation</i> | Noise cancellation is a digital signal process that removes noise from an audio signal corrupted by real-world interferences such as HVAC, office noise, crowd noise, or road noise. Generally, there are two parts of a noise cancellation algorithm: a method to detect the noise and a method to remove the noise. The Polycom noise cancellation algorithm (patent pending) is capable of removing 10 dB or higher of noise with no degradation at all to the resulting speech signal. This method does not attenuate speech, and removes noise during both speech and idle periods. |
| <i>NOM</i> | NOM refers to the number of open microphones in a system. |
| <i>NOM Attenuation</i> | NOM attenuation is the gain applied to the overall system gain to the microphone signals to compensate for how many microphones are open. The amount of attenuation is calculated by $10 \cdot \log_{10}(\text{NOM})$. |
| <i>NOM Bus</i> | A NOM bus carries signal information as well as NOM information (i.e., the number of open microphones in the system, NOM). |
| <i>Presets</i> | Presets correspond to configuration parameters that have been previously saved to EEPROM. |

Room Gain

The room gain of a conferencing system refers to the relative levels of the signal sent to the line output to your amplifier (before any amplification) and the level of this signal that is reflected at the microphone input (after microphone amplification). If the electrical level of the reflected signal picked up by the microphone is the same as the level of the electrical signal sent from the AEC to the line output to your amplifier, the room gain of this microphone channel is said to be 0 dB. If the reflected signal picked up by the microphone is higher than the level of the signal sent to the line output to your amplifier, that microphone channel has positive room gain. The more positive the room gain, the harder the AEC must work to determine which signal is an echo and which is a local speech signal.

INDEX

A

ASPI Bus 3, 6, 9, 11, 43, 48, 54
Automatic Gain Control (AGC) 3, 30, 54
Automixer, Automatic Microphone Mixer 2, 3, 20, 32, 54

C

Calibration 15
Compliance 43

D

Digital Bus 2, 3, 24, 55

E

Echo Cancellation 2, 3, 31, 43, 46
EF Bus 6, 9, 10, 23, 24, 31, 43, 48, 55
EF Bus Reference 24, 29
EF200 Phone Add 4, 9, 10, 55
Equalization 55
Equalizer 3

F

Factory Default 11

G

Ground 48, 49
Grounding 7

I

Inputs 2, 3, 5, 6, 7, 9, 15

L

LCD Menu 3, 5, 15, 18, 26
Link, Linked 3, 23, 29, 55

M

Matrix, Matrix Mixer 2, 3, 23, 34
Mix Minus 24, 54

N

Noise Cancellation 2, 3, 30, 43, 46, 55
NOM 24, 31, 55
NOM Attenuation 55
NOM Bus 24, 55

O

Outputs 13, 31

P

Parallel Remote Control 3, 6
Phantom Power 6, 15, 31, 43
Phoenix Connectors 3, 4, 7, 9, 49
Pin 1 Compatible 7

R

Reference, AEC 2, 9, 17–18, 24, 31, 55
Remote Control. See RS-232, Serial Remote Control or Parallel Remote Control.

Reverberation 46

Room Gain 13, 38, 56

RS-232, Serial Remote Control 3, 4, 6, 9, 15, 24, 27, 30, 43, 48

S

Signal Generator 2, 3